



WHI Listing Index Construction Joints

Joint Systems		Joints							GrabberGard Products			
		Bottom of Wall	Floor to Floor	Floor to Wall	Head of Wall	Wall to Wall	Max Joint Width	Class	Movement Capabilities	I F C	F F C	F F S
	JWA/PHV 60-01					3/4	II	25.0			✓	1
	JWA/PHV 120-03					3/4	II	33.0			✓	1 & 2
	JWA/PHV 120-04								✓	✓	✓	2
	JWA/PHV 120-07								✓	✓		2
	JWA/PV 60-02					3/4	II	33.0	✓	✓		1
	JWA/PV 120-04					3/4	II	33.0			✓	1 & 2
	JWA/PV 120-05					1	II	25.0	✓	✓	✓	1 & 2
	JWA/PV 240-01					2	II	12.5			✓	4

Curtain Wall		Wall Exterior							Framing				
		Steel	Glass	Tilt-Up Panels	Concrete Panels	Aluminum Panels	Brick Veneer	Stone Veneer	EIFS	S t e e l S t r u c t u r e	A l u m i n i u m	N / A	HOURLY
	JWA/PH 120-03									✓			2



John Wagner & Associates Inc.
 dba GRABBER CONSTRUCTION PRODUCTS
 205 Mason Circle, Concord, CA, 94520

GrabberGard EFS

Design No. JWA/PH 120-03

Horizontal or Vertical Expansion/Control Joints

Test Standards: ASTM E-119, ULC S115-M95

L-Rating At Ambient < 1 CFM/Lin Ft

L-Rating At 400° F < 1 CFM/Lin Ft

Test Furnace Internal Positive Pressure Differential – 2.5 Pa (0.01 in. of water) Minimum

Penetrating Material & Size	Max Width	Fire "F" Rating	Temp. "FT" Rating
Horizontal Joints	10"	up to 2hrs	30 min

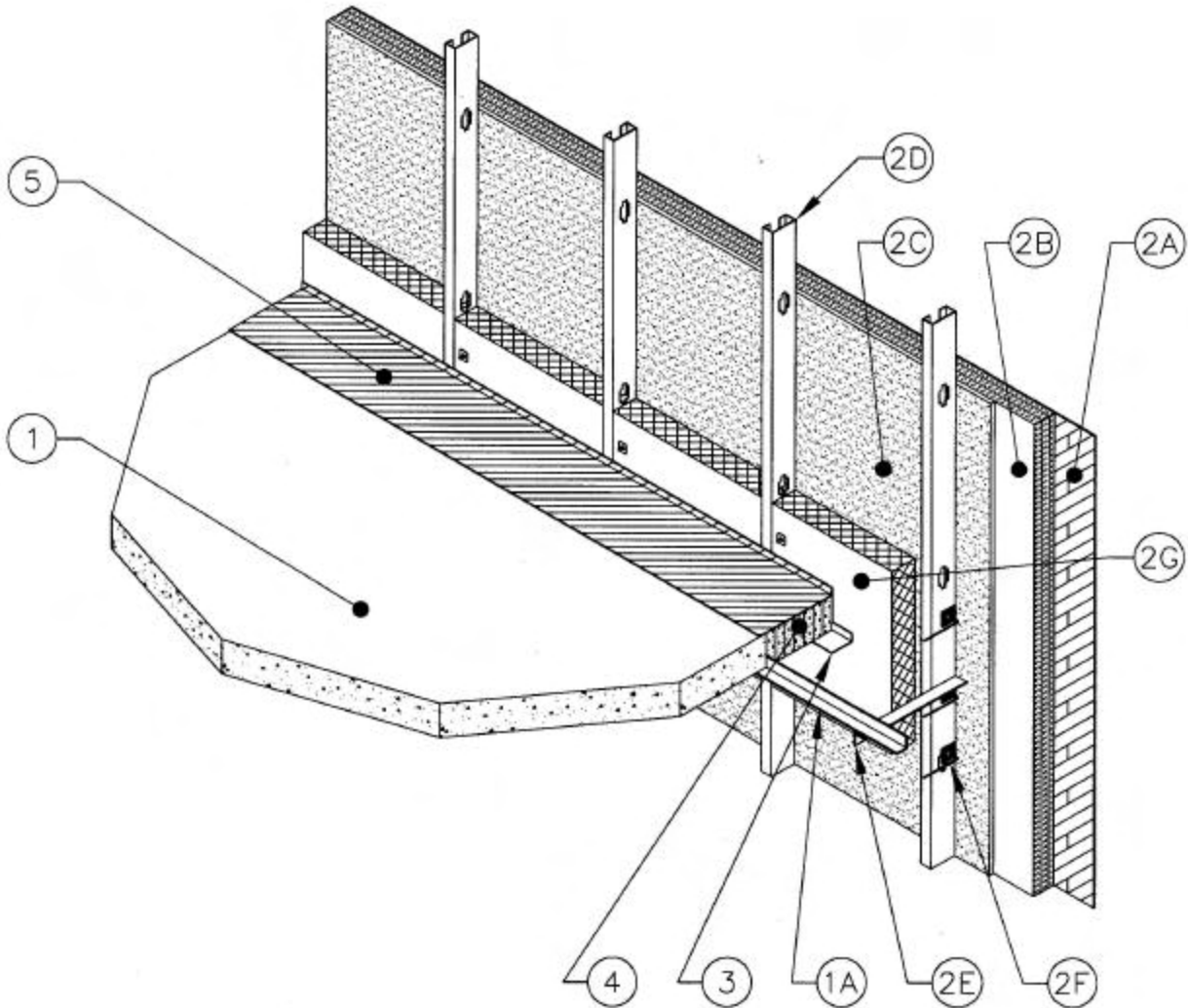

System Design Instructions

1. **Floor/Ceiling Assemblies:** ASTM E-119 and CAN/ULC S101 up to 2 hour rated floor/ceiling assemblies; Cast in place normal or light density concrete floor/ceiling assemblies having a minimum cross section thickness of 4-1/2in. (114mm) and including the following:
 - A. **Steel Angle** – Perimeter of floor assembly to be provide with min 1-1/2 by 1-1/2 by 3/16 in. thick cast-in-place structural steel angle for weld-attachment of EIFS mounting attachment (Item 2E).



2. **Exterior Insulation Finish System:** This Exterior Insulation Finish System (EIFS) to be constructed of the materials and in the manner described by the EIFS wall manufacturer's installation instructions and shall include the following features:
 - A. **Cementitious Finish Coating** – Min 1/16 in. thick cementitious finish coating applied as per EIFS wall manufacturer's instructions.
 - B. **Expanded Polystyrene (EPS) Foam Boards** – Max 3 in. thickness of expanded polystyrene foam boards applied to exterior gypsum board as per EIFS wall manufacturer's instructions.
 - C. **Exterior Gypsum Board** – Min 1/2 in. thick exterior gypsum boards applied to steel studs with min 1 in. long pan head screws at 10 OC. Gypsum boards installed as per EIFS wall manufacturer's instructions.
 - D. **Steel Stud Framing** – Vertical framing members shall be min 3-5/8 in. by 1-1/4 in., 16 ga steel "C" studs. Attachment shall be according to EIFS wall manufacturer's guidelines. Vertical framing shall not exceed a spacing of 24 in. OC.
 - E. **Mounting Attachment** – Min 1-1/2 in. by 1-1/2 in. by 3/16 in. thick structural steel angle weld-attached to steel stud framing and cast-in-place structural angle located max 48 in. OC.
 - F. **Impaling Pins** – Min 6-1/2 in. long 12 ga steel pins, welded or mechanically fastened to flat side of steel studs and bent 90 degrees perpendicular to the face of the curtain wall insulation. Pins to be installed at max 8 in. OC vertically and at max 24 in. OC horizontally.
 - G. **Curtain Wall Insulation** – Min 4 in. 4 pcf mineral wool board, unfaced or faced on one side with aluminum foil/scrim vapor retarder, supplied in min 24 in. wide boards. Mineral wool board to be impaled on pins, flush with interior surface of steel studs, and secured in position with min 1-1/4 in. square steel clinch shields. Fill the cavity of all "C" shaped studs with insulation. A single piece of 24 in. wide mineral wool to extend a min 12 in. below and min 8 in. above the of the bottom and top surfaces of the concrete floor assembly.

3. **Firestop System Component 1:** Steel angle manufactured from min 16 ga steel to be welded or mechanically fastened to vertical steel studs. Angle to be installed such that the horizontal leg of angle is min 4 in. below the top surface of the concrete floor assembly to support the mineral wool insulation (Item 4). Size and installation of steel angle is as follows:
 - A. **Joints ranging from 0 to max 2 in.** – No angle is required.
 - B. **Joints ranging from min 2 to max 6 in.** – Min 1 by 1 in. angle to be installed.
 - C. **Joints ranging from min 6 to max 10 in.** – Min 1 by 3 in. angle to be installed such that the 3 in. leg is installed horizontally with the 1 in. leg installed vertically.

4. **Firestop System Component 2:** Filler material mineral rock wool or ceramic fiber insulation with a minimum density of 46 PCF (68 kg/m³) with mineral wool fibers running perpendicular to curtain wall and compressed a minimum of 20% into the joint space at a minimum depth of 4 in. (102 mm). As an alternative, the min 4 pcf mineral wool maybe installed such that the mineral wool fibers run parallel to curtain wall and are compressed a minimum of 40% into the joint space at a minimum depth of 4in. (102 mm).

5. **Firestop System Component 3:** John Wagner & Assoc. Inc. dba GRABBER CONSRTUCTION PRODUCTS – GrabberGard EFS* (mastic) for horizontal applications sprayed into place with a minimum wet film thickness of 3/32 in. (2.5 mm). Always overlap GrabberGard EFS* onto the surface of the substrate a minimum of 1in. (25 mm). Do not thin GrabberGard EFS* firestop mastic when spraying, use equipment capable of applying material as supplied.

*WH Labeled Component



Design No. JWA/PHV 60-01

Metal Decking to Vertical Wall Assemblies

Test Standards: UL 2079 Rating: 1 hour "F"

Test Standards: ULC S115-M95 Rating: 1 hour "FTH"

Test Furnace Internal Positive Pressure Differential – 2.5 Pa (0.01 in. of water) Minimum
Joint System Cycled 500 Times at 10 cycles per Minute – 25% Compression or Extension

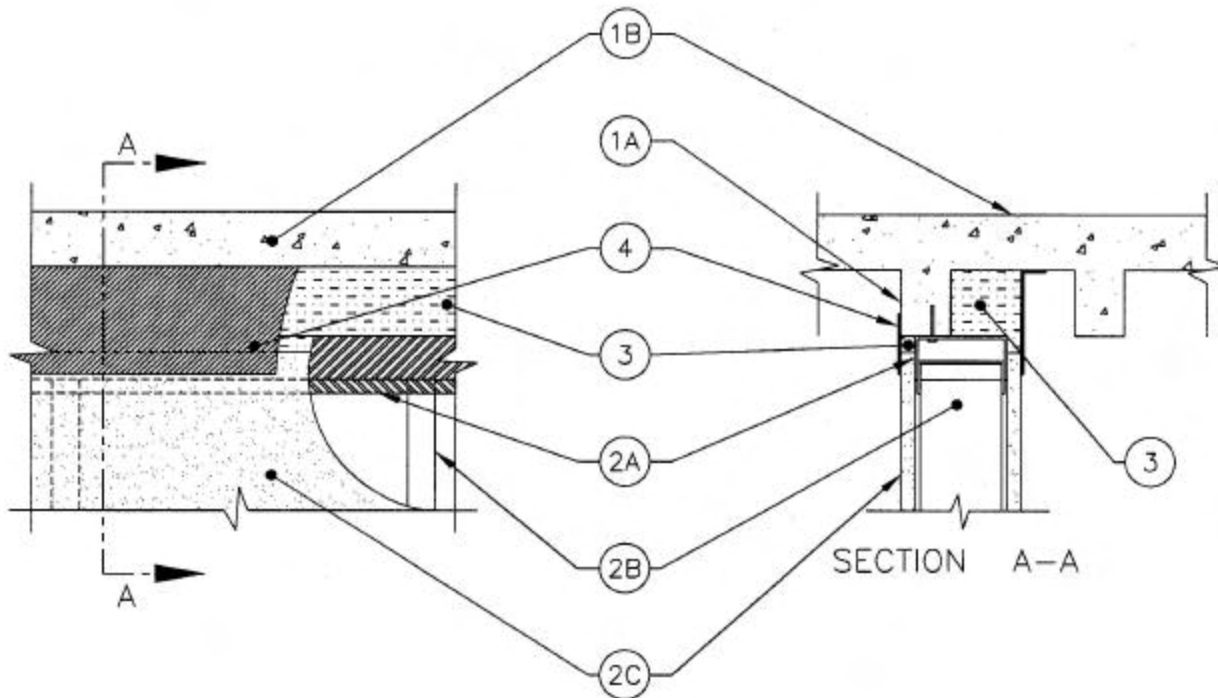

System Design Instructions

- Floor/Ceiling Assembly:** 1 hour ASTM E-119 or CAN/ULC S101 fluted steel deck roof/ceiling or floor/ceiling assemblies.
 - Steel Deck:** Galvanized steel fluted units.
 - Concrete:** Min. 2-1/2" (63mm) deep concrete, as measured from the top plane of the steel deck (1A).
 - Wall Assembly:** 1 hour ASTM E-119 or ULC S101 metal framed gypsum wallboard (GWB) wall assemblies and shall include the following:
 - Ceiling Runner & Deflection Channel:** 3-5/8" (91mm) x 1-1/2" (38mm) U-shaped runner with optional min. 24 Ga. with min. 2" (50mm) deep legs U-shaped deflection channel. When deflection channel is used, ceiling runner is installed within the deflection channel maintaining a 3/4" (19mm) gap between the top of the ceiling runner and top of the deflection channel and deflection channel is attached to floor/ceiling assembly. When deflection channel is not used ceiling runner is fastened directly to floor/ceiling assembly with steel fasteners or by welds spaced max. 24" (600mm) OC.
 - A1. Slotted Ceiling Runner:** (As an alternative to 2A) 3-5/8" (91mm) U-shaped runner with slotted flanges, fastened to floor/ceiling assembly.
 - B. Studs:** 3-5/8" (91mm) wide 'C' studs, spaced 24" (600mm), cut 1/2" (13mm) to 3/4" (19mm) less in length than assembly height.
 - C. Wallboard:** 5/8" (16mm) Type X gypsum wallboard, straight cut 3/4" (19mm) below lower surface of floor/ceiling assembly.
- The hourly F Rating of the firestop system is equal to the hourly fire rating of the wall assembly in which it is installed.**
- Firestop System, Component 1:** Filler material- Min. 2 in. (50 mm) thick min. 4 PCF (64kg/m³) density mineral wool insulation compressed min. 25% between the top track and the underside of the top of the flute. Additional pieces of min. 5/8 in. (19 mm) thickness of min. 4 PCF (64kg/m³) density mineral wool insulation compressed min. 25% between the top of the gypsum wallboard and the underside of steel deck. Filler material to be flush with both sides of wall assembly.
 - Firestop System, Component 2:** Min. 1/16" (60mil) dry thickness of John Wagner & Assoc. Inc. dba GRABBER CONSTRUCTION PRODUCTS – GrabberGard EFS* sprayed or brushed on each side of the wall assembly, fully covering all filler material and overlapping a min of 1" (25mm) onto the metal deck and wall assembly.

*WH Labeled Component



Design No. JWA/PHV 120-03

Metal Decking to Vertical Wall Assemblies

Rating: Up to 2 Hours "FTH"

Test Standards: ASTM E-814, UL 2079, ULC S115-M95

Test Furnace Internal Positive Pressure Differential – 2.5 Pa (0.01 in. of water) Minimum

Max Joint Width at Top of Wall – 3/4" (19 mm)

Joint System Cycled 500 Times at 10 Cycles Per Minute – 33% Compression or Extension

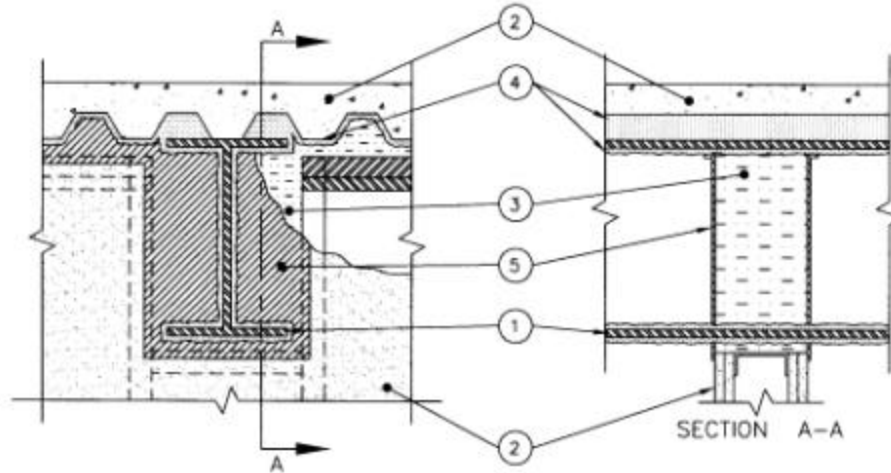

System Design Instructions

- 1. Penetrating Item:** Steel beam or open-web steel joist, as specified in the individual roof/ceiling or floor/ceiling design, used to support fluted steel deck. Structural steel support oriented perpendicular to wall assembly. Where open-web steel joist pass through the fire rated wall, 3/8 in. diamond mesh expanded steel lath having a nom weight of 1.7 to 3.4 lbs per sq yd shall be secured to one side of each joist with galvanized steel tie wire and the lath shall be fully covered with spray-applied fire resistive material applied in accordance with the specifications in the individual roof/ceiling or floor/ceiling design. The clearance between the top of the gypsum board and the bottom of the spray-applied structural steel member to be 0" to max 3/4" (19 mm).
- 2. Roof/Ceiling of Floor/Ceiling Fire Separation:** 1 or 2 hour ASTM E-119 or CAN/ULC S101 fluted steel deck (GWB) roof/ceiling or floor/ceiling assemblies.
Wall Fire Separation: 1 or 2 hour ASTM E-119 or CAN/ULC S101 metal framed gypsum wall board (GWB) wall assemblies consisting of a single or a double top track consisting of a single top track with a deflection channel or slip track.
The hourly rating of the joint system is equal to the lesser hourly rating of either the roof/floor/ceiling or the wall assembly.
- 3. Firestop System, Component 1:** Filler material, Min 46 PCF (68 kg/m³) density mineral wool insulation at a min depth of 6-1/8" (157mm) compressed into each flute opening in the steel deck and into the framed beam opening in the wall assembly flush with both sides of the wall assembly.
- 4. Firestop System, Component 2:** Cafco 300 or WR Grace Type MK-6/HY applied to the underside of the roof/ceiling or floor/ceiling assembly and all surfaces of the structural steel support. Spray-applied in accordance with the specifications in the individual roof/ceiling or floor/ceiling design.
- 5. Firestop System, Component 3:**
Method 1: Spray or Brush: One heavy coat of John Wagner & Assoc. Inc. dba GRABBER CONSTRUCTION PRODUCTS – GrabberGard EFS*, 1/16" (63 mil) dry thickness, on both sides of the assembly, fully covering all voids and overlapping a minimum of 1" (25mm) onto the metal deck, steel beam and wall assembly.
Method 2: Caulk: Min 1/8" (3 mm) thickness of John Wagner & Assoc. Inc. dba GRABBER CONSTRUCTION PRODUCTS – GrabberGard EFC* or GrabberGard IFC*, applied between the gypsum wall board and spray applied fire resistance material on both sides of the assembly, fully covering all voids, and overlapping a minimum of 1/8" (3 mm) onto the metal deck, steel beam and wall assembly.

*WH Labeled Component



John Wagner & Associates Inc.
 dba GRABBER CONSTRUCTION PRODUCTS
 205 Mason Circle, Concord, CA, 94520

GrabberGard EFC
 GrabberGard IFC
 GrabberGard EFS

Design No. JWA/PHV 120-04

**Fire Rated Non-Flammable Acoustic Firestop Sealant

Horizontal or Vertical (floor/ceiling and walls)

Test Standards: ASTM E-814, UL 1479, ULC S115-M95

Test Furnace Internal Positive Pressure Differential – 2.5 Pa (0.01 in. of water) Minimum

ASTM E-814		ULC S115
"F" Rating	"T" Rating	"FTH" Rating
2 Hour	2 Hour	2 Hour

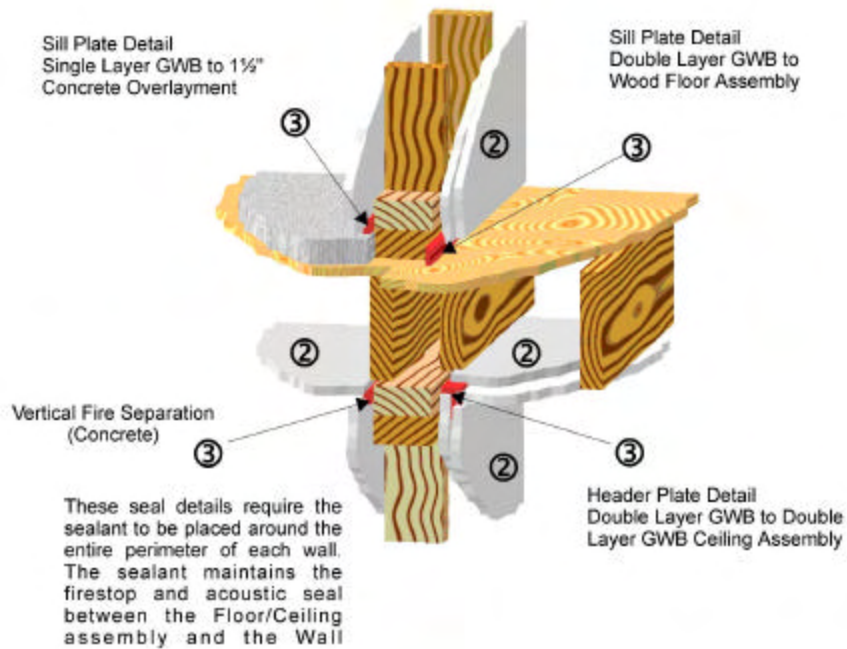

System Design Instructions

1. **Penetrating Item:** Not applicable.
2. **Floor/Ceiling or Wall Fire Separations:** 1 and 2 hour rated ASTM E-119 or CAN/ULC S101 concrete, metal or wood framed fire rated gypsum wall board (GWB) floor/ceiling/wall assemblies.
3. **Firestop System Component 1:** John Wagner & Assoc. Inc. dba GRABBER CONSTRUCTION PRODUCTS – GrabberGard EFC* or GrabberGard IFC* firestop sealant at a minimum bead diameter of 3/8" (10mm) caulked into the corner and behind the GWB around the entire perimeter of the fire rated wall assembly. Attach gypsum wall board (GWB) membranes into the sealant within 15 min of sealant placement or prior to sealant skinning.
4. **Firestop System Component 2:** Filler material not required.

Optional - When max separation between bottom of ceiling membrane and wall membrane is less than 1/16 of an inch.

5. **Firestop System Component 3:** John Wagner & Assoc. Inc. dba GRABBER CONSTRUCTION PRODUCTS – GrabberGard EFS* firestop spray applied a minimum dry thickness of 1/16" (2mm) sprayed into the corner and behind the GWB around the entire perimeter of the fire rated wall assembly. Attach gypsum wall board (GWB) membranes into the sealant within 15 min of sealant placement or prior to sealant skinning

*WH Labeled Component

**The acoustic claims have not been verified by Intertek Testing Services



John Wagner & Associates Inc.
 dba GRABBER CONSTRUCTION PRODUCTS
 205 Mason Circle, Concord, CA, 94520

GrabberGard EFC
 GrabberGard IFC

Design No. JWA/PHV 120-07

Horizontal or Vertical Static Stair Joints

Test Standards: UL 2079, ULC S115-M95

Test Furnace Internal Positive Pressure Differential – 2.5 Pa (0.01 in. of water) Minimum

Configuration 1

Penetrating Material & Size	Max Width	UL 2079 "F" Rating	ULC S115-M95 "FTH" Rating
Vertical and Horizontal Joints	2"	up to 2hrs	up to 2hrs

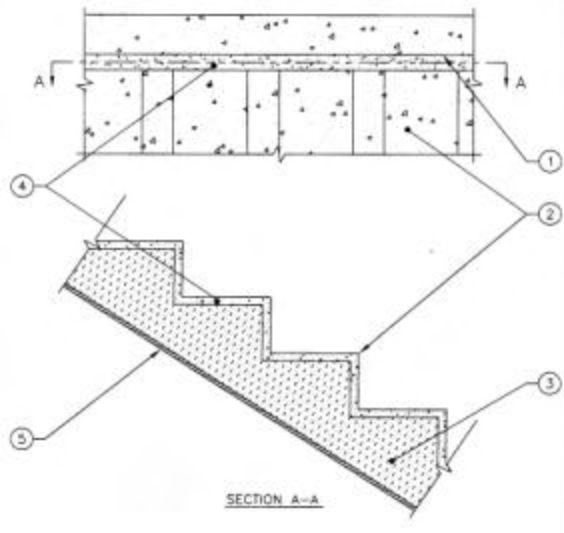

Configuration 2

Penetrating Material & Size	Max Width	UL 2079 "F" Rating	ULC S115-M95 "FTH" Rating
Vertical and Horizontal Joints	1/2"	up to 2hrs	up to 2hrs

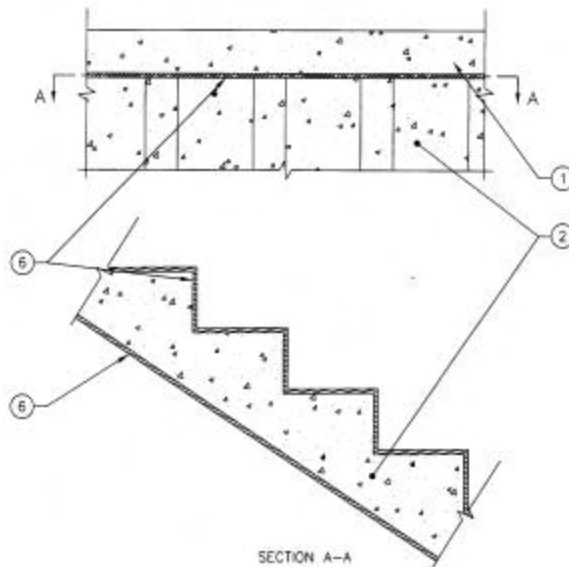



John Wagner & Associates Inc.
dba GRABBER CONSTRUCTION PRODUCTS
205 Mason Circle, Concord, CA, 94520

GrabberGard EFC
GrabberGard IFC

JWA/PHV 120-07

System Design Instructions

1. **Wall Assemblies:** ASTM E-119 and CAN/ULC S101 up to 2 hour fire rated wall assemblies as follows:
 - a) Cast in place concrete wall assemblies having a minimum cross section thickness of 5" (125mm) or;
 - b) Hollow or concrete filled unit masonry (concrete block) wall assemblies laid up with mortar having a minimum cross section thickness of 8" (200mm).
2. **Concrete Stair Assemblies:** Min 2 hour fire-rated concrete stair assembly having a min thickness of 6-1/2 in.

Configuration 1

3. **Firestop System Component 1:** Filler material mineral rock wool or ceramic fiber insulation with a minimum density of 4-6 PCF (68 kg/m³) compressed a minimum of 25% into the joint space at a minimum depth of 5" (120 mm). Recess filler material to accommodate for grout (Item 4) placement on top side of staircase. Recess filler material to accommodate sealant placement (Item 5) placement on underside of staircase.
4. **Firestop System Component 2:** Min. 1" (25 mm) thick cementitious grout installed into joint on topside of staircase assembly.
5. **Firestop System Component 3:** John Wagner & Assoc. Inc. dba GRABBER CONSTRUCTION PRODUCTS – GrabberGard EFC* or GrabberGard IFC* for vertical or horizontal applications installed at a minimum thickness of 1/2 in (12mm) into joint on underside of staircase assembly.

Configuration 2

6. **Firestop System Component 1:** John Wagner & Assoc. Inc. dba GRABBER CONSTRUCTION PRODUCTS – GrabberGard EFC* or GrabberGard IFC* for vertical or horizontal applications installed at a minimum thickness of 1/2 in (12mm) into joint on top and underside of staircase assembly.

***WH Labeled Component**



John Wagner & Associates Inc.
dba GRABBER CONSTRUCTION PRODUCTS
205 Mason Circle, Concord, CA, 94520

GrabberGard EFC
GrabberGard IFC

Design No. JWA/PV 60-02

Metal Decking to Vertical Wall Assemblies

Rating: Up to 1 Hour "FTH"

Test Standards: ULC S115-M95

Rating: Up to 1 Hour "F Rating"

Test Standards: ASTM E-814, UL 2079

Test Furnace Internal Positive Pressure Differential – 2.5 Pa (0.01 in. of water) Minimum
Joint System Cycled 500 Times at 10 Cycles Per Minute – 33% Compression or Extension

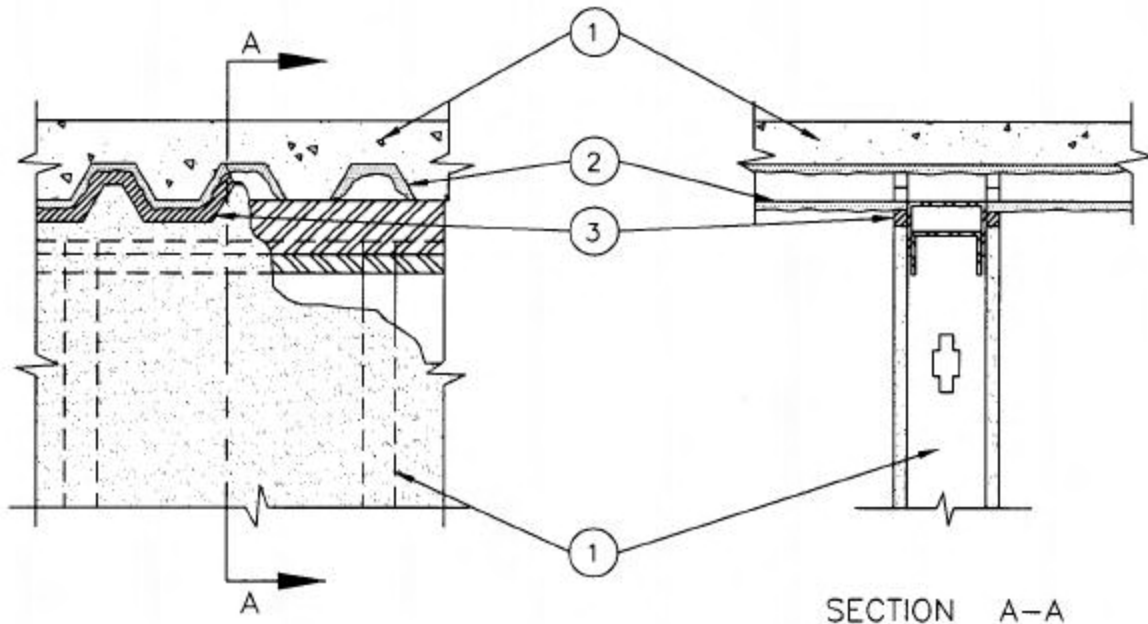

System Design Instructions

- 1. Floor/Ceiling Fire Separation:** 1 or 2 hour ASTM E-119 or CAN/ULC S101 fluted steel deck roof/ceiling or floor/ceiling assemblies.
Wall Fire Separation: 1 hour ASTM E-119 or ULC S101 metal framed gypsum wallboard (GWB) wall assemblies with a single slip track ceiling runner or a double top track system consisting of a single top track with a deflection channel. Gypsum board cut to profile of coated fluted steel deck with a nominal 3/4 in. (19mm) joint between the top of the gypsum board and the underside of the spray applied fire resistive material. Steel studs to be cut 1/2 to 3/4 in. less than assembly height.
- 2. Firestop System Component 1:** Min 3/8 in. to max 15/16 in. thickness of MK-6 spray applied fire resistive material applied to the underside of the floor/ceiling assembly.
- 3. Firestop System Component 2:** John Wagner & Assoc. Inc. dba GRABBER CONSTRUCTION PRODUCTS – GrabberGard EFC* or GrabberGard IFC* into the gap between the top of the gypsum wallboard and the spray applied fire resistive material to the full depth of the gypsum board membrane on both sides of the wall assembly.

*WH Labeled Component



Design No. JWA/PV 120-03

Single Penetrations
 Vertical (walls)

Test Standards: ASTM E-814, UL 1479: open and closed system, ULC S115-M95: closed systems
 Positive Pressure Differential – 2.5 Pa (0.01 in. of water) Minimum

Penetrating Material & Size	Max Hole Size	Annular Space	E 814 & "F" Rating	UL 1479 "T" Rating	S115-M95 "F" Rating	Fire/Hose "FH" Rating	Temp Rating "FTH" Rating
PVC Plastic pipe to 2"	3"	1/4"	0 Hr	Up to 40 min	Up to 2 Hr	0 Hr	Up to 40 min
CcPVC Plastic pipe to 2"	3"	1/4"	0 Hr	Up to 40 min	Up to 2 Hr	0 Hr	Up to 40 min
CPVC Plastic pipe to 2"	3-5/8"	1/2"	Up to 2 Hr	Up to 20 min	Up to 2 Hr	Up to 2 Hr	Up to 20 min
CPVC Plastic pipe to 2"	3"	1/4"	0 Hr	Up to 115 min	Up to 2 Hr	0 Hr	Up to 115 min
X-Linked Polyethylene tubing to 1" ID	2-1/2"	1/2"	0 Hr	Up to 70 min	Up to 2 Hr	0 Hr	Up to 70 min
X-Linked Polyethylene tubing to 1" ID	2"	1/2"	Up to 2Hr	Up to 15 min	Up to 2Hr	Up to 2Hr	Up to 15 min

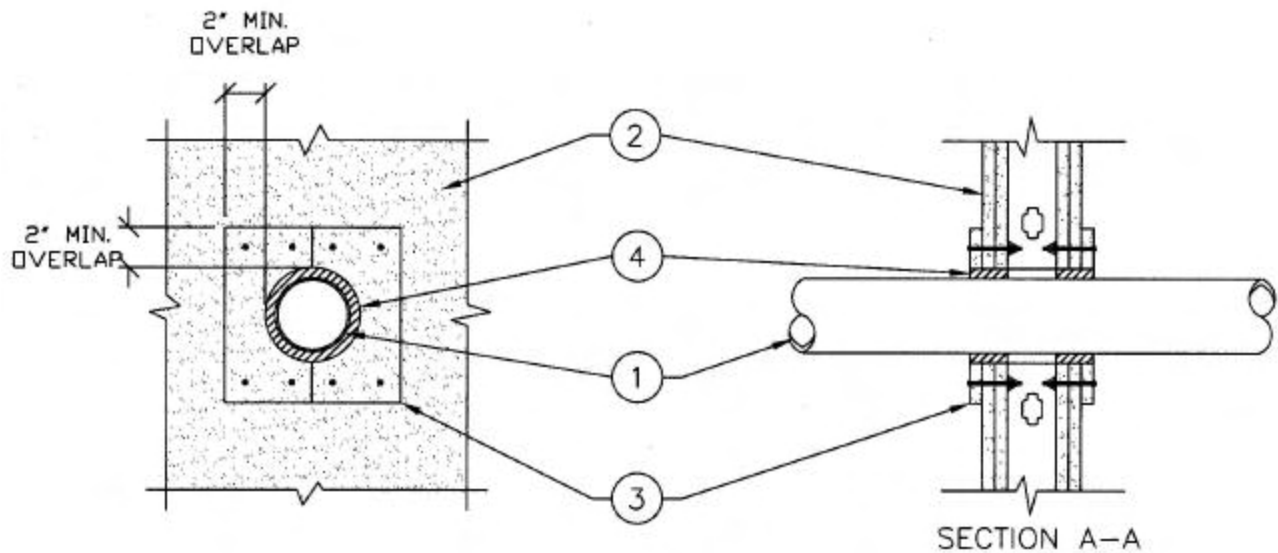

System Design Instructions

- 1. Penetrating Item:** Centered in hole, see table above.
- 2. Wall Fire Separations:** 2 hour rated ASTM E-119 or CAN/ULC S101 metal or wood framed insulated gypsum wall board (GWB) wall assemblies.
- 3. Firestop System; Component 1:** One layer of 5/8" Type "X" gypsum wallboard collar securely fastened to gypsum wallboard with drywall anchors. Caulk a 3/8" (10mm) bead around perimeter edges of GWB collar after installation.
- 4. Firestop System; Component 2:** John Wagner & Assoc. Inc. dba GRABBER CONSTRUCTION PRODUCTS – GrabberGard IFC* fully filling the annular space to the full depth of the membrane.

*WH Labeled Component



Design No. JWA/PV 120-04

Metal Decking to Vertical Wall Assemblies

Rating: Up to 2 Hours "FTH"

Test Standards: ASTM E-814, UL 2079, ULC S115-M95

Test Furnace Internal Positive Pressure Differential – 2.5 Pa (0.01 in. of water) Minimum
Joint System Cycled 500 Times at 10 Cycles Per Minute – 33% Compression or Extension

Method 1

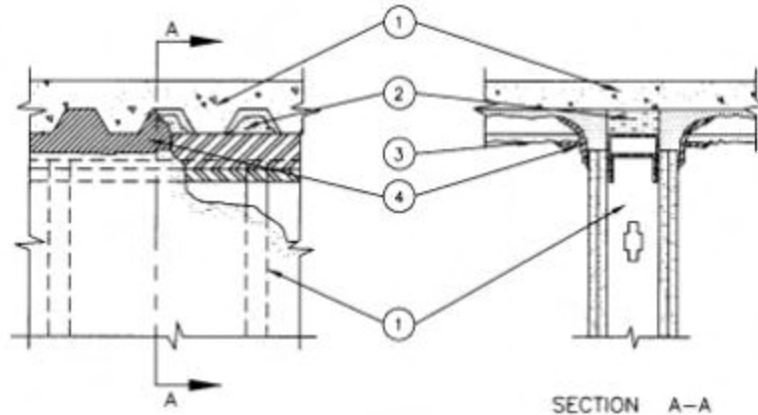

Method 2

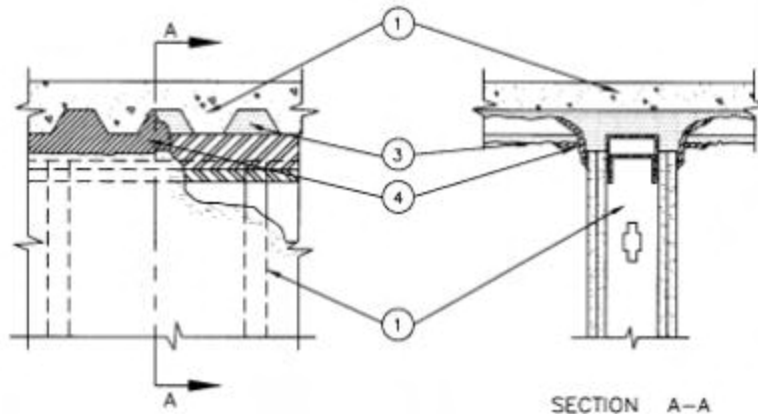

System Design Instructions

1. Floor/Ceiling Fire Separation: 1 or 2 hour ASTM E-119 or CAN/ULC S101 fluted steel deck (GWB) roof/ceiling or floor/ceiling assemblies.

Wall Fire Separation: 1 or 2 hour ASTM E-119 or ULC S101 metal framed gypsum wall board (GWB) wall assemblies with a double top track consisting of a single top track with a deflection channel or slip track.

The hourly F Rating of the firestop system is equal to the hourly fire rating of the wall assembly in which it is installed.

2. Firestop System, Component 1:

Method 1: Filler material, 4 pcf mineral wool or 2.5 pcf fiberglass insulation compressed into each flute opening in the steel deck as a backing material for the Caeco 300.

Method 2: Filler material, Caeco 300 applied into each flute opening in the steel deck.

3. Firestop System, Component 2: Min 3/8" to max 15/16" thickness of Caeco 300 applied to the underside of the floor/ceiling assembly with a 3" diameter radius formed at the steel deck/wall board interface on both sides of the wall assembly.

4. Firestop System, Component 3: Spray or brush one heavy coat of John Wagner & Assoc. Inc. dba GRABBER CONSTRUCTION PRODUCTS – GrabberGard EFS*, 1/8" (3mil) thick, on both sides of the assembly, fully covering all voids and overlapping a minimum of 1" (25mm) onto the metal deck and wall assembly.

*WH Labeled Component



Design No. JWA/PV 120-05

Metal Decking to Vertical Wall Assemblies

Rating: Up to 2 Hours "FTH"

Test Standards: ASTM E-814, UL 1479, ULC S115-M95

Test Furnace Internal Positive Pressure Differential – 2.5 Pa (0.01 in. of water) Minimum

Max Joint Width – 1 in.

Joint System Cycled 500 Times at 10 Cycles Per Minute – 25% Compression or Extension

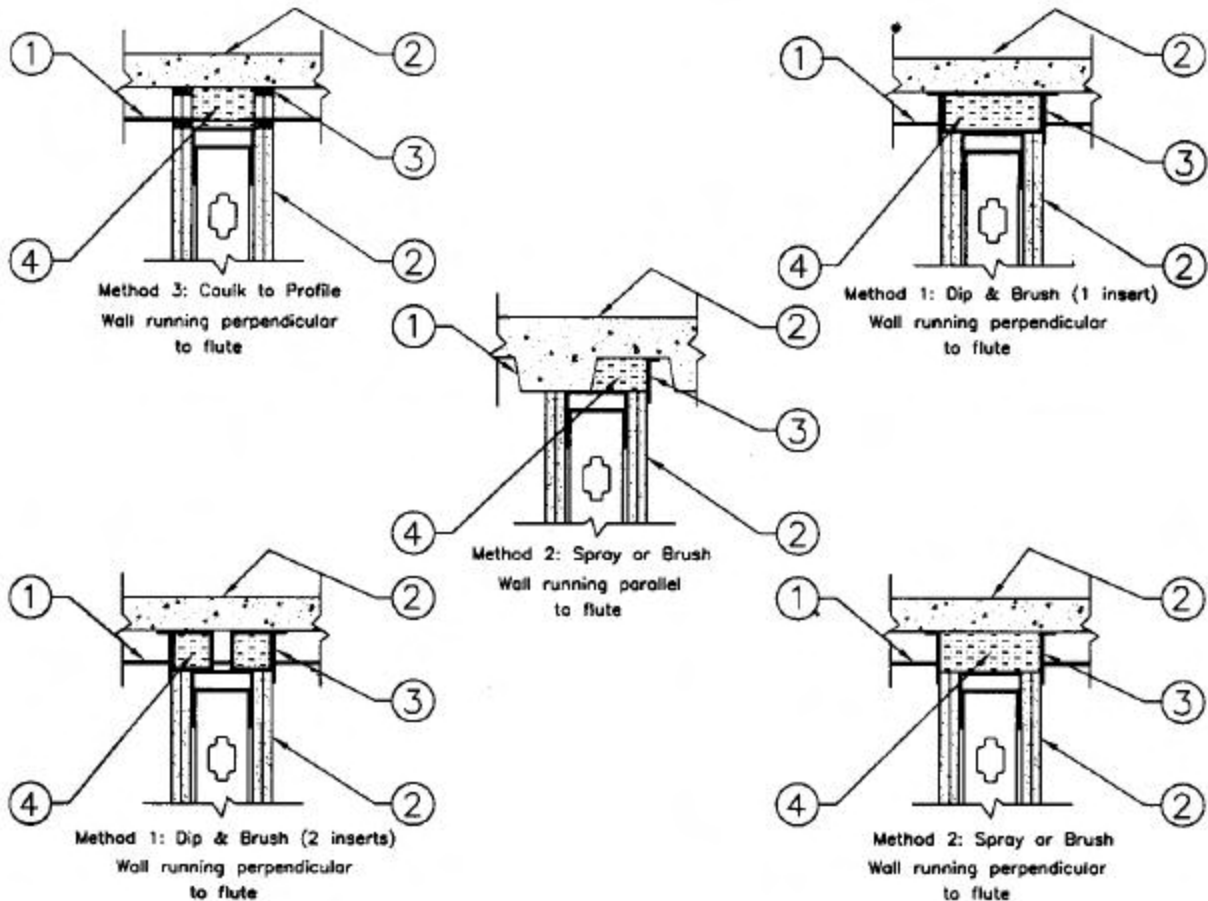

System Design Instructions

- 1. Steel Decking:** Minimum 22 gauge or equal galvanized steel decking with up to 3½" (88mm) flute height firmly supported, with or without concrete cover.
- 2. Floor/Ceiling Fire Separations:**
 - a) 1 and 2 hour ASTM E-119 or CAN/ULC S101 fluted steel deck roof/ceiling or floor/ceiling assemblies.
- 3. Wall Fire Separations Terminating at Fluted Steel Deck:**
 - a) 1 and 2 hour ASTM E-119 or CAN/ULC S101 metal or wood framed gypsum wall board (GWB) assemblies or;
 - b) Cast in place normal or light density concrete floor/ceiling assemblies having a minimum cross section thickness of 4½" (114mm) or;
 - c) Cast in place concrete wall assemblies having a minimum cross section thickness of 6" (150mm) or;
 - d) Hollow or concrete filled unit masonry (concrete block) wall assemblies laid up with mortar having a minimum cross section thickness of 8" (200mm).



4. Firestop System Component 1:

Method 1: Dip & Brush: Dip each insert individually and fully coat in GrabberGard EFS* (firestop mastic), insert into flute opening to the desired depth. Brush exposed surface of insert on both sides smooth overlapping ½" (13mm) onto metal decking and/or the wall assembly to ensure complete coverage and no small gaps or pin holes exist. Brush excess material between flute foot and deflection/slip track to the next open flute cavity, sealing the seam between the steel decking and the deflection/slip track. If larger spaces are evident, fill tightly with mineral wool and brush a 1/16" (60mil) coat of GrabberGard EFS* to fully cover the area.

Method 2: Spray or Brush: Install each insert at the desired location and spray or brush one heavy coat of GrabberGard EFS* 1/8" (120mil) thick, on both sides of the assembly, fully covering all voids and overlapping a minimum of ½"(13mm) onto the metal deck and wall assembly

Method 3: Caulk to profile: Cut the gypsum wallboard to the profile of the deck and install to within ¾" of the deck. Caulk GrabberGard EFC* or GrabberGard IFC* into the gap between the gypsum board and the deck to the depth of the gypsum board membrane.

5. Firestop System Component 2: Flute Opening: Insert of 4-6 PCF (68kg/m³) mineral wool, cut 10% larger than the opening area. Depth: Cut the mineral wool insert to a depth of 5" (125mm) for the single insert detail, for the two-piece detail cut two 2½" deep inserts. Two-piece details can be installed one on each side of the assembly flush with the membrane surface. Additional pieces of mineral wool batt insulation are to be compressed 33 percent in thickness and are installed to completely fill the gap above the top of the wall and the bottom of the steel floor units, flush with both surfaces of wall. Mineral wool inserts can be installed in any of the configurations detailed in Methods 1 and 2. Exception: when flutes are running parallel with the wall, cut 4-6 PCF (68kg/m³) mineral wool inserts to the desired shape, 10% larger than the opening area and compress into the open cavity. All details require sealant as outlined in Section 3 of this system design.

6. Firestop System Component 3: (Optional) – When gaps between top of wall and bottom of the steel deck is less than or equal to 3/4 in. – Nom 1 in. diam polyethylene rod compressed and firmly packed into the nom 3/4 in. gap between the top of the wall and the bottom of the steel deck and forming material (Item 5) in areas of fluted deck. Backer rod compressed to be flush with surface of wall.

*WH Labeled Component



Design No. JWA/PV 240-01

Concrete Deck to Vertical Wall Assemblies

Test Standards: ASTM E-814, UL 2079, CAN/ULC S115-M95

L-Rating At Ambient < 1 CFM/Lin Ft

L-Rating At 400° F < 1 CFM/Lin Ft

Test Furnace Internal Positive Pressure Differential – 2.5 Pa (0.01 in. of water) Minimum

Max. Joint Movement – 12.5% Compression or Extension

Construction Joint	UL 2079		CAN/ULC S115-M95		
	Max Width	Assembly Rating	Fire "F" Rating	Fire/Hose "FH" Rating	Temp. "FTH" Rating
Horizontal Joints	2"	4 Hrs	4 Hrs	4 Hrs	4 Hrs

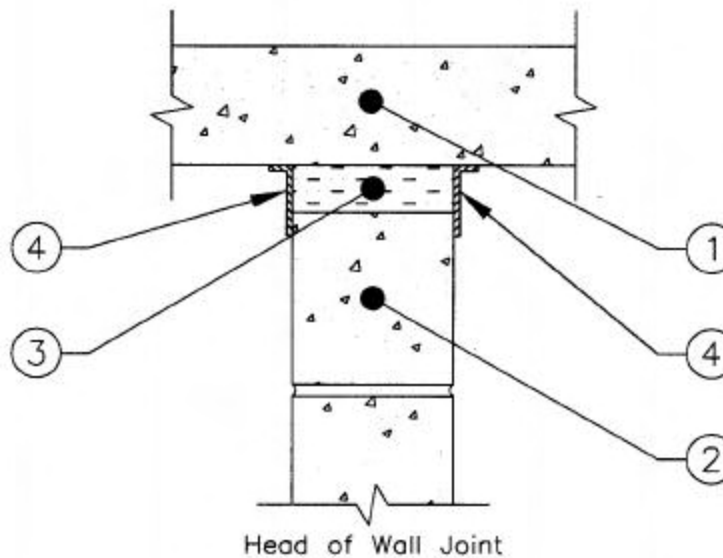

System Design Instructions

1. **Floor/Ceiling Assemblies:** Cast in place normal or light density concrete floor/ceiling assemblies having a minimum cross section thickness of 5" (125 mm)
2. **Wall Assemblies:** ASTM E-119 or CAN/ULC S101 up to 4 hour rated wall assemblies conforming to as follows:
 - a) Cast in place concrete wall assemblies having a minimum cross section thickness of 6-3/4" (171mm) or;
 - b) Hollow or concrete filled unit masonry (concrete block) wall assemblies laid up with mortar having a minimum cross section thickness of 8" (200mm).
3. **Firestop System – Component 1** – Filler material mineral rock wool or ceramic fiber insulation with a min density of 4 PCF (64 kg/m³) compressed a minimum of 40% into the joint space flush with both sides of wall assembly.
4. **Firestop System – Component 2** – John Wagner & Assoc. Inc. dba GRABBER CONSTRUCTION PRODUCTS – GrabberGard EFS* – Minimum dry film thickness 1/16" (1.5mm) sprayed or brushed into place completely covering fillet material and overlapping onto all concrete surface a minimum of 1" (25mm).

*WH Labeled Component