

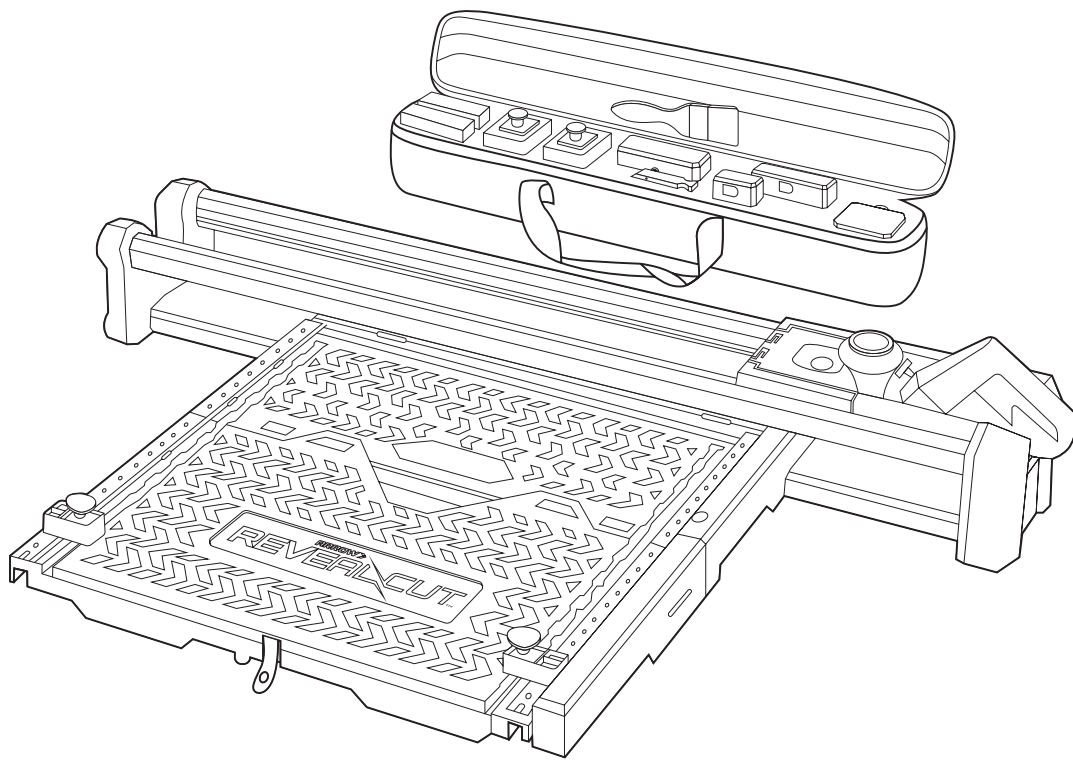

OPERATOR'S MANUAL

REVEALCUT™ ACOUSTIC TILE-CUTTING WORKSTATION MODEL RC200, RC400



Your RevealCut™ Acoustic Tile-Cutting Workstation has been engineered and manufactured to Arrow's high standards for dependability, easy operation and safety. If properly cared for, it will give you years of reliable, trouble-free performance.



WARNING: To reduce risk of injury, the user must read and understand this operator's manual.

Thank you for buying RevealCut.

SAVE THIS MANUAL FOR FUTURE REFERENCE

TABLE OF CONTENTS

■ PRODUCT SPECIFICATIONS	3
■ RULES FOR SAFE OPERATION	4
■ GLOSSARY OF TERMS	5
■ PARTS LIST	6
■ SET UP	6
▪ Unpacking the Workstation	6
▪ Securing the Work Area	7
■ BASIC OPERATION.....	8
■ INSTALLING SIZING CARTRIDGE AND BLADES.....	9
■ INSTALLING PROFILE FRAME, CARTRIDGE AND BLADES	10
■ MEASURING TILE TO SIZE	12
■ CUTTING TILES.....	13
■ OUT-OF-SQUARE CUTS.....	15
■ REPEAT AND LINEAR LIGHTING CUTS.....	16
▪ Repeat Cuts	16
▪ Linear Lighting Cuts	16
■ USING PLATFORM EXTENSION BARS (RC400 MODEL ONLY)	17
■ MAINTENANCE	18
■ TROUBLESHOOTING	19
■ TECHNICAL QUESTIONS / SERVICE	19
■ WARRANTY	20

PRODUCT SPECIFICATIONS

Your RevealCut Acoustic Tile-Cutting Workstation is designed to cut tiles to size and install a factory-grade finished edge on both mineral fiber (wet felt) and fiberglass acoustic ceiling tiles from most manufacturers.

Tile Thickness	:	5/8" to 1 1/2"
Tile Size	:	RC200 cuts 2'x2' tiles RC400 cuts 4'x4', 2'x4', and 2'x2' tiles
Edge Profiles	:	Lay-In Square Tegular Angled Tegular Beveled Square Tegular
Nominal Sizing	:	Can adjust +/- 1/16" for nominal sized tiles
Blades	:	Carbon steel with TaC (tetrahedral amorphous carbon) coating for up to 200 tiles cut per blade.
Multiple Cuts	:	Jig stops can be used for multiple same-sized cuts.
Linear Lighting Cuts	:	Jig stops can be used for linear lighting cuts.

Your RevealCut workstation comes from the factory with precise alignment of key parts. **DO NOT ATTEMPT TO DISASSEMBLE OR REASSEMBLE PLATFORM OR RAIL COMPONENTS.** Call RevealCut customer service for help with replacement parts or repair.

RULES FOR SAFE OPERATION

- Keep your work area clean and free of debris.
- Always secure the workstation to a flat, sturdy surface. Use the supplied mounting screws.
- Never use the workstation on a ladder.
- Never use the workstation on the floor.
- When carrying the workstation, use the molded handles on the platform. To prevent possible contact with installed blades, avoid carrying the workstation by the rails.
- Remove blades when workstation is not in use.
- Never place hands under rails. Exposed blades can cause injury.
- Use care when handling or replacing blades. **REVEALCUT BLADES ARE EXTREMELY SHARP.**
- Dispose of used blades properly. Use sharps container provided with your workstation.
- Wear eye protection when installing finished tiles.

GLOSSARY OF TERMS

Platform: The flat, molded platform that supports the tile during cutting operation. RC200 has a single platform. RC400 has two platforms.

Rulers: Used for measuring tile cuts. Each RevealCut workstation has two matching rulers.

Platform Extension: Molded parts which attach to the platform to support oversized tiles. Available on RC400 only.

Tile Stop: Raised rail on right side of platform. Used to square tiles to cutting blades.

Jig Stop: Adjustable red rectangular stops that slide on platforms. Used for making non-square cuts, multiple cuts of same size and linear lighting cuts.

Rails: The extruded aluminum rails that extend the length of the RevealCut workstation which the cutting cars slide on.

Cutting Cars: The two independent cars which slide on the rails. The “sizing car” with long handle cuts the tile to size. The “profile car” with round handle installs the tile edge profile.

Sizing Cartridge: The black plastic insert that holds the large sizing blade. This comes in two sizes.

Sizing Blade: The large cutting blade which mounts to the sizing cartridge and car and cuts tile to size.

Profile Frame: Square die-cast frames which accommodate the profile cartridge. There are three frames, each one accommodating two tile thicknesses.

Profile Cartridge: Square cartridge that holds the profile blades. Used for cutting-edge profile. This comes in three styles – square tegular, angled tegular and beveled square tegular.

Nominal Adjustment: The thumbscrew on the top of each profile cartridge that moves the blades up or down $1/16$ " to accommodate nominally sized tiles.

Profile Blade: The short cutting blade which mounts to the profile cartridge and car and cuts the edge profile.

Blade Dispenser: Black cartridge that contains fresh blades. Comes in two sizes – one for sizing blades and one for profile blades. Dispenses fresh blades safely.

Sharps Container: Long black box with slotted top for disposing of used blades.

Parts Kit: Contains mounting screws and spare thumbscrews.

Parts List

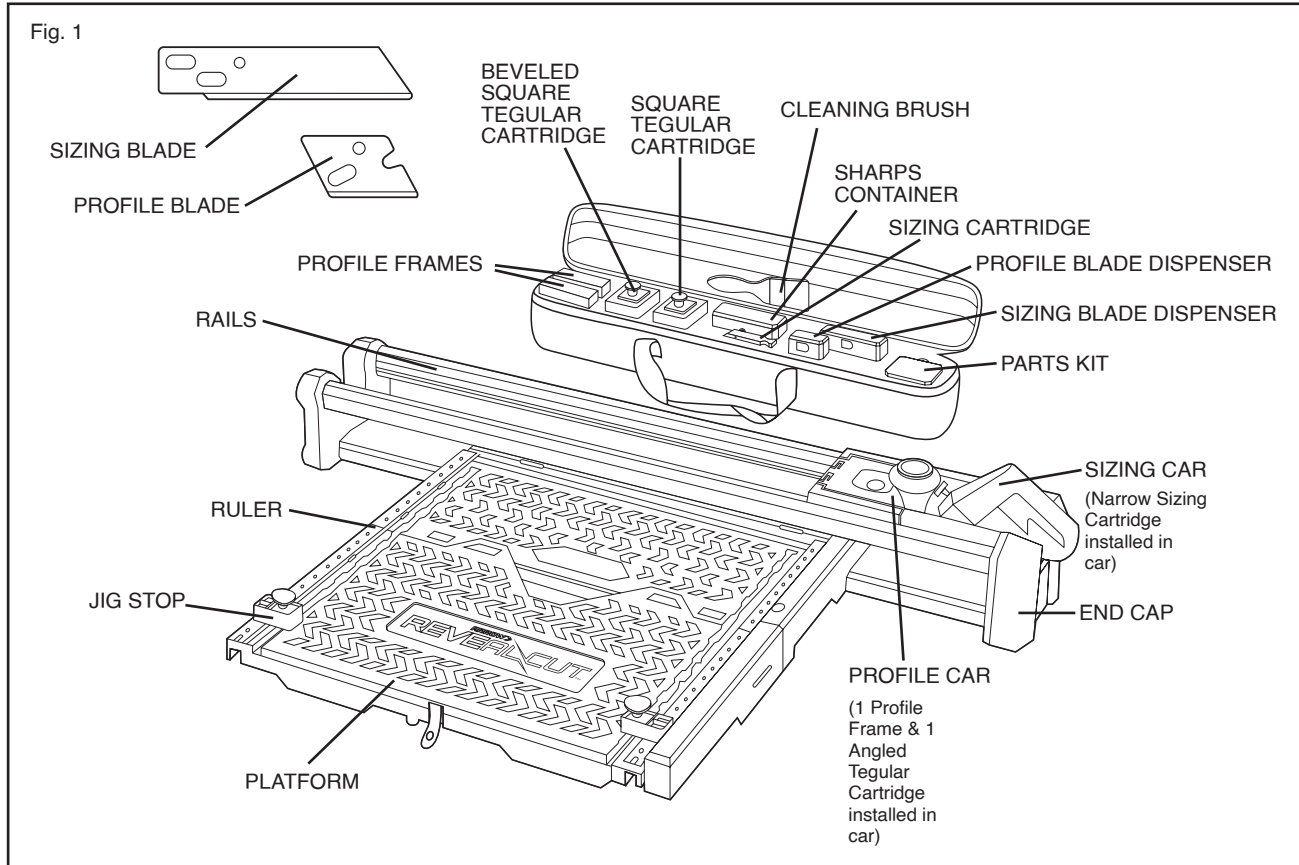

Set Up

The RevealCut workstation comes calibrated from the factory and ready to use right out of the box, with all parts and accessories needed to get to work. Minimal set-up is required.

Unpacking the Workstation

- Remove workstation from its carry bag. Keep bag in a safe, clean area for easy retrieval.
- Remove accessory bag from between rails.
- When carrying the workstation, use the molded handles in the platform. Avoid carrying by the rails to prevent possible contact with installed blades.
- To open the workstation, release the rubber clasp holding the hinged platform together and carefully open the platform to its full size.

Securing the Work Area

- Set up your workstation in an area that is clear and free of debris with plenty of room to move tiles on and off the platform.
- The RevealCut workstation should be used on a flat, sturdy surface, preferably 36" - 41" high. A plywood sheet supported by two sawhorses is ideal for this purpose. A plywood sheet on a Baker scaffold shelf also may be used.
- To avoid accidental damage or possible injury, do not attempt to use RevealCut on the floor or on a ladder.
- Use mounting screws provided in the Parts Kit to affix the workstation to the plywood sheet using screw holes located on platform base between the rails.

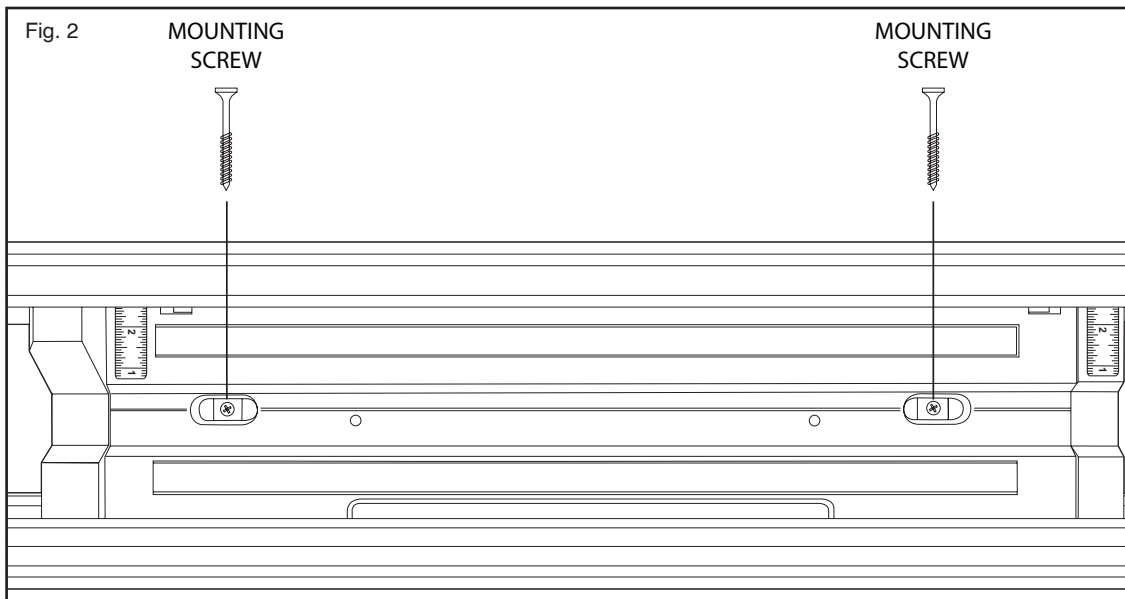

BASIC OPERATION

Your RevealCut workstation operates by moving the cutting blades installed in the cutting cars across the tile edge. The tile gets aligned on the platform flush against the tile stop and with the rear edge of the tile at the preferred size measurement on the ruler.

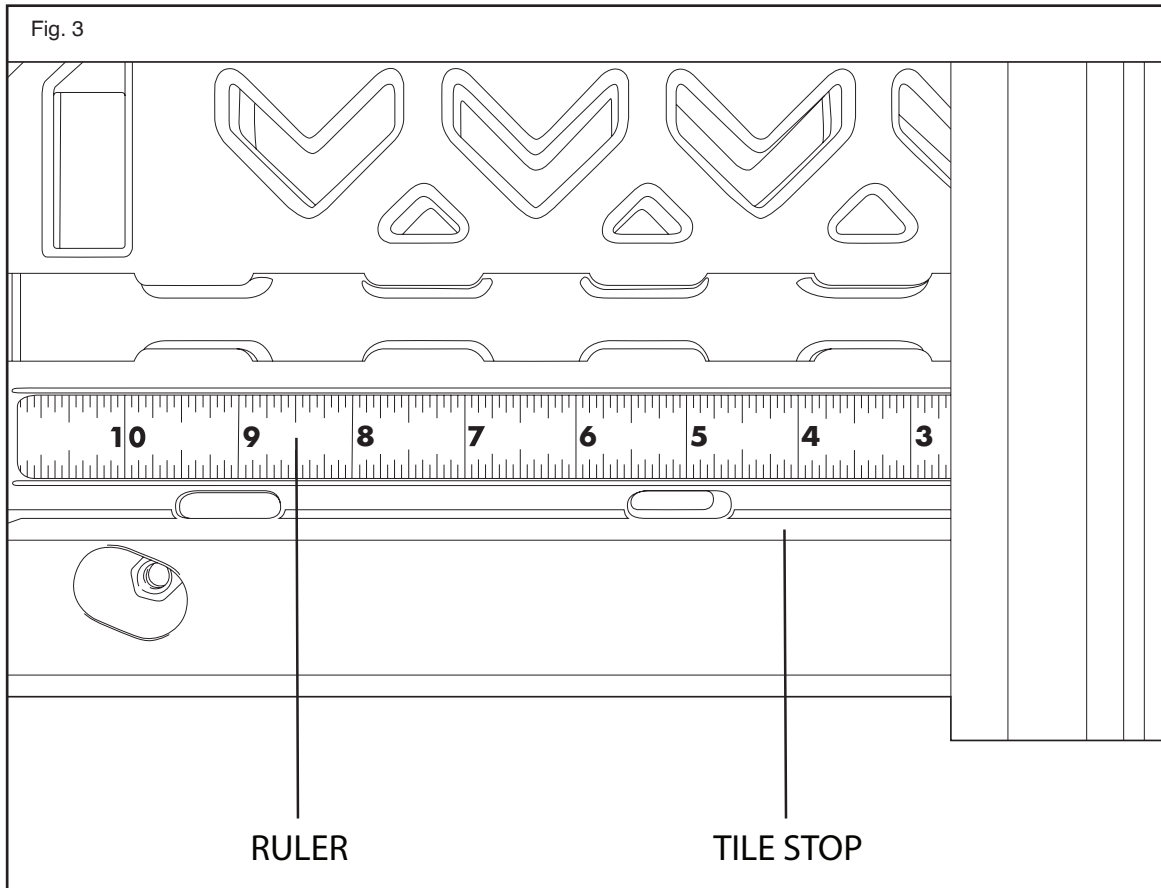

The first cutting car, the “sizing car,” cuts the edge of the tile to the desired size. The second cutting car, the “profile car,” installs the factory-grade profile edge. (See Fig. 1) Both the profile blades and the sizing blades are specially designed for cutting ceiling tiles. Each will cut up to 200 tiles before they need to be replaced.

To obtain the proper results, the workstation must be configured for the type of tile being cut. The configuration is obtained by matching the proper sizing cartridge to the tile thickness and by matching the proper profile frame and profile cartridge to the proper tile thickness and profile style.

It is important to follow the directions in this manual for proper set up. Once you have done it a few times, set up is easy and intuitive.

INSTALLING SIZING CARTRIDGE AND BLADES

The RevealCut workstation comes with two sizing cartridges to accommodate different thicknesses of tile. For tile sizes from $\frac{5}{8}$ " to 1", the narrow cartridge is used. The narrow cartridge comes pre-installed in the unit. For tile sizes from $1\frac{1}{4}$ " to $1\frac{1}{2}$ ", the wide cartridge is used. This cartridge comes packed in the accessory bag.

- Select which cartridge to use with your tile: (Fig. 4)
 - Narrow cartridge for tile thicknesses up to 1 inch
 - Wide cartridge for tile thicknesses over 1 inch
- To remove installed cartridge from sizing car, move sizing car at least 4" from end of rail to allow handle to move freely. (Fig. 5)
- Loosen thumbscrew on top of sizing car near handle. Pull handle back and grab cartridge by square grip section on the end. Push cartridge downward until it disengages from sizing car housing. Pull cartridge off axle inside the handle.
- Next, remove thumbscrew from the cartridge and lift metal blade cover up.
- Carefully remove a fresh blade from the blade dispenser by sliding the red slider to the right. The blade will dispense from the end of the dispenser. **USE CARE – BLADES ARE EXTREMELY SHARP.**
- Install blade into cartridge by aligning guide holes in blade to raised guides on the cartridge. The blade will fit only one way.
- Replace the metal blade cover over the blade and tightly screw the thumbscrew back into place.
- Ensure sizing blade is sitting flush and secure in sizing cartridge.
- With sharp edge facing down toward platform, replace cartridge into sizing car. You will feel a snap when the back end of the cartridge engages the axle inside the car.
- Pull cartridge up into sizing car housing.
- Tighten large thumbscrew on top of sizing car, making sure it is secure.
- The sizing blade is now installed. To remove and replace a used blade, use the same procedure. Use sharps container to dispose of used blades.

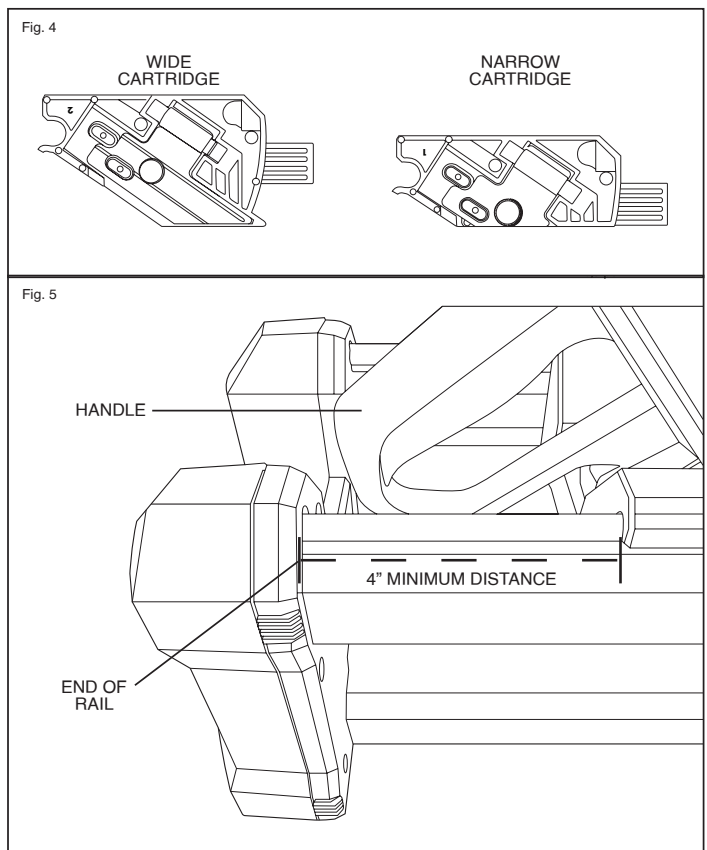

INSTALLING PROFILE FRAME, CARTRIDGE AND BLADES

The RevealCut workstation comes with three profile frames. (Fig. 6) Two are located in the accessory bag; the third comes pre-installed in the profile car.

The profile frame determines the depth of the profile cut and is used to match the profile to a specific tile thickness. Each frame is marked with a specific

measurement in the corner of the frame to indicate corresponding tile thickness. Each profile frame accommodates two different thicknesses of tile depending on its orientation in the car.

- Red Frame: $\frac{5}{8}$ " and $\frac{3}{4}$ " thick tiles
- Green Frame: $\frac{7}{8}$ " and 1" thick tiles
- Blue Frame: $1\frac{1}{4}$ " and $1\frac{1}{2}$ " thick tiles

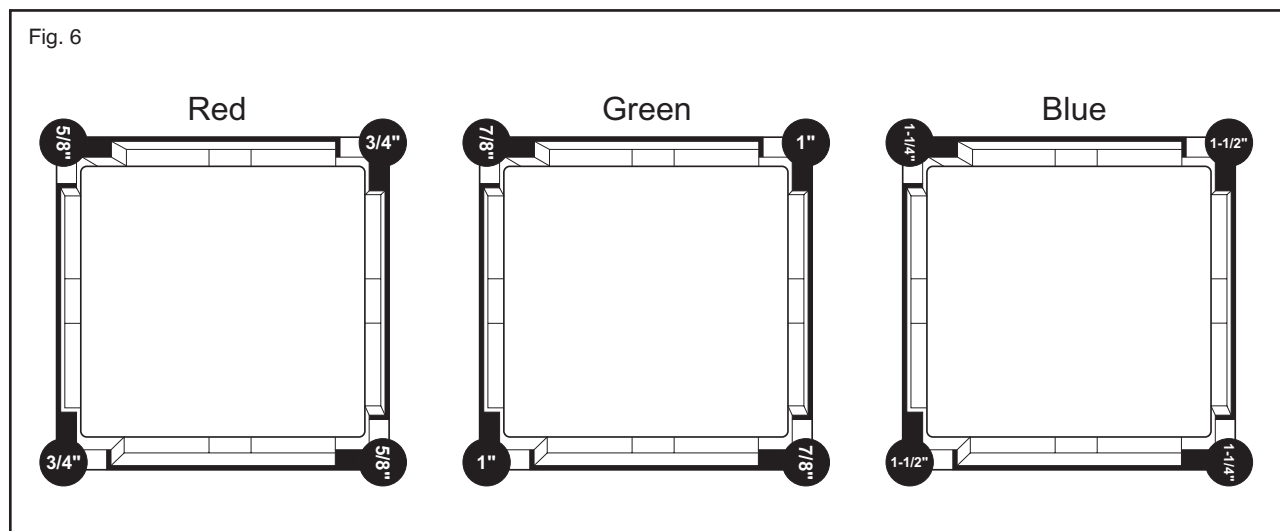

Your workstation also comes with three profile cartridges. These are designed to cut angled tegular profiles, square tegular profiles and beveled square tegular profiles. The profile cartridges are labelled to indicate the specific profile they will cut. (Fig. 7) Each holds two profile blades – one to make the horizontal lip cut and one to make the vertical hang-down cut. The beveled square tegular cartridge uses a third blade to cut the beveled edge.

To set up the workstation for cutting profile edges, use the following procedure:

- Select which profile cartridge will be used – square tegular, angled tegular or beveled square tegular. For lay-in tiles, the profile car is not used. The sizing car will make a simple lay-in cut.
- Remove the thumbscrews on the bottom of the cartridge selected and lift the metal blade covers up.

- Carefully remove fresh blades from the profile blade dispenser by sliding the red slider to the right. The blades will dispense from the end of the dispenser.
USE CARE – BLADES ARE EXTREMELY SHARP.
- Install blades into cartridge by aligning guide holes in blades to raised guides on the cartridge. The blades will fit only one way.
- Replace the metal blade holders over the blades and tightly screw thumbscrews back into place.

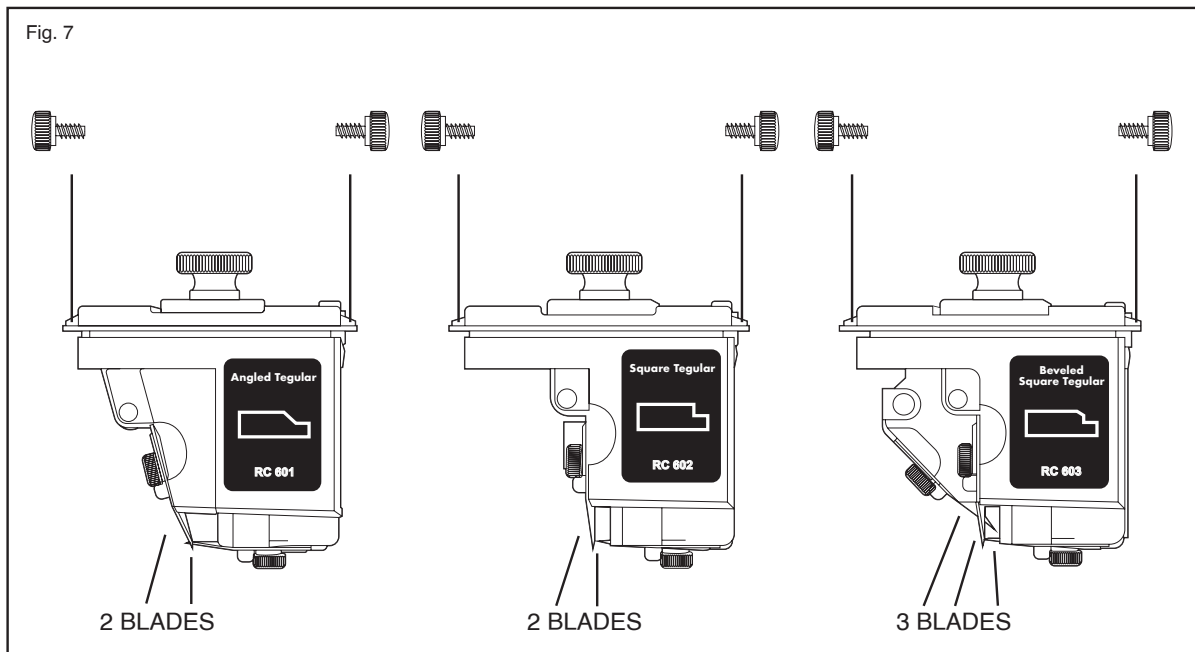

The profile blades are now installed. To remove and replace used blades, use the same procedure. Use the sharps container to dispose of used blades.

- Next, remove two small thumbscrews on either side of the top edge of the cartridge and set aside for the next step.
- Select which profile frame to use based on the tile thickness to be cut. Profile frames are color coded and include sizing indicators in the corners.
- Hold profile frame facing you with desired tile size indicated in upper-left corner.
- Insert profile cartridge into frame with arrows on top of cartridge pointing toward the right.
- Secure cartridge into frame with the two previously removed small thumbscrews on either side of cartridge. Be sure to tighten securely.
- Loosen top of profile car by loosening large hand screw inside round handle. Raise top of profile car.
- Insert profile frame and profile cartridge assembly into profile car with arrows on top of cartridge matching direction of arrows on top of car.
- Close top of profile car and tighten screw inside round handle.

Profile car assembly is now ready to use.

MEASURING TILE TO SIZE

The RevealCut workstation makes measuring tiles to the proper size fast and easy – even on walls that are not perfectly square. And, because both the sizing cut and profile edge finish are completed in the same operation, it eliminates the need for scribing once tiles are sized.

To obtain the proper measurement for cutting:

- Measure grid face to face on one side of the grid opening and again on the opposite side.
- Add twice the lip width of the tile to each measurement.

Here's an example:

- Grid measures 9" on both sides. Tile to be installed has $\frac{3}{8}$ " lip. Cut measurement becomes 9" plus $2 \times \frac{3}{8}$ or $9 \frac{3}{4}$ for each side.
- Grid measures 14" on both sides. Tile to be installed has $\frac{3}{16}$ " lip. Cut measurement becomes 14" plus $2 \times \frac{3}{16}$ or $14 \frac{3}{8}$ " for each side.

For out-of-square walls, follow the same process for each side of the grid. For example:

- Grid measures 9" on right side and $9 \frac{1}{8}$ " on left side. Tile to be installed has $\frac{3}{8}$ " lip. In this case, right side measurement becomes 9" plus $2 \times \frac{3}{8}$ or $9 \frac{3}{4}$. Left side measurement becomes $9 \frac{1}{8}$ " plus $2 \times \frac{3}{8}$ or $9 \frac{7}{8}$.

CUTTING TILES

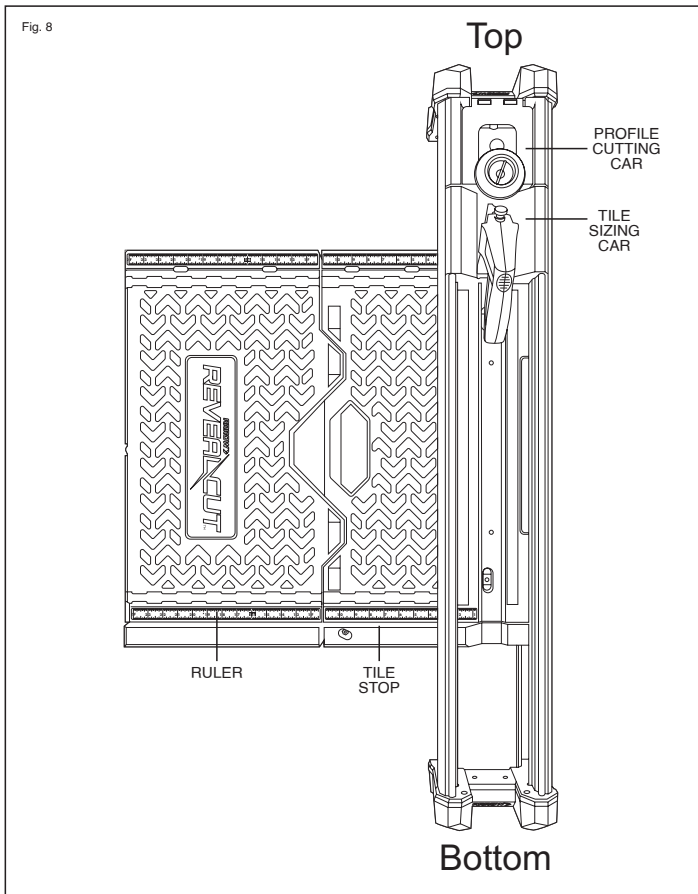

is no need to try to cut the tile in a single pass. For many mineral fiber tiles you will need to make two or up to three passes of the sizing blade to cut completely through the tile. This is normal. Fiberglass tiles will usually require only a single pass.

- On final sizing pass, leave sizing car on bottom of rails, opposite the profile car.
- Next, make a single pass with the profile car to finish the tile edge.
- Remove tile.
- Return profile car to top of rail.

Examine your test cut to see if it matches the tile's finished edge. Adjusting the lip depth up or down is the most common adjustment needed. This typically is caused by tiles being slightly thinner or thicker than their rated dimensions.

First, make a test cut to optimize the tool settings by following these steps:

- Begin with both cutting cars positioned at the top of the rails.
- Place tile finished face up on the platform.
- Ensure tile is flush to the tile stop on platform. This ensures tile is square to the cutting blades.
- Align rear of tile to desired cut size on ruler.
- Use your hand to hold tile down gently on platform.
- Depress long handle of sizing car and pull sizing blade across tile. Make a complete pass. Note: There

If the tile looks good, there is no need for further adjustment. However, if cut needs to move up or down, the following adjustments can be made:

- For minor adjustments ($\pm 1/16$ ") use the fine-adjustment feature located at the top of the profile cartridge.
- Loosen but do not remove the big thumbscrew on top of the cartridge. Once loosened, press down gently on the top of the thumbscrew to disengage bottom half of cartridge. You can now gently slide the thumbscrew to one side or the other. (Fig. 9)
- To move the cut down $1/16$ " , slide

thumbscrew up so that the $+1/16$ " indicator is showing on cartridge base. Tighten the thumbscrew again and repeat your test cut from the beginning. (Fig. 9)

- To move the cut up $1/16$ ", slide thumbscrew down so that the $-1/16$ indicator is showing on cartridge base. Tighten the thumbscrew again and repeat your test cut from the beginning.

Occasionally, the cut depth may be off by more than $1/16$ " due to the hang-down depth of the tile profile. If this is the case, you will need to change the profile frame to the next tile thickness – up or down as needed – and make another test cut.

For example:

- You are cutting a $5/8$ " thick tile with a deeper-than-average hang down.
- Your first test cut with the $5/8$ " profile frame is too high – it's off by $1/8$ ".
- Reconfigure profile cartridge assembly to use $3/4$ " frame setting instead of $5/8$ ".
- Make another test cut.
- Adjust up or down $1/16$ " as described above to secure proper dimension.

Once your test cut matches the tile's factory edge, you are ready to start cutting tiles.

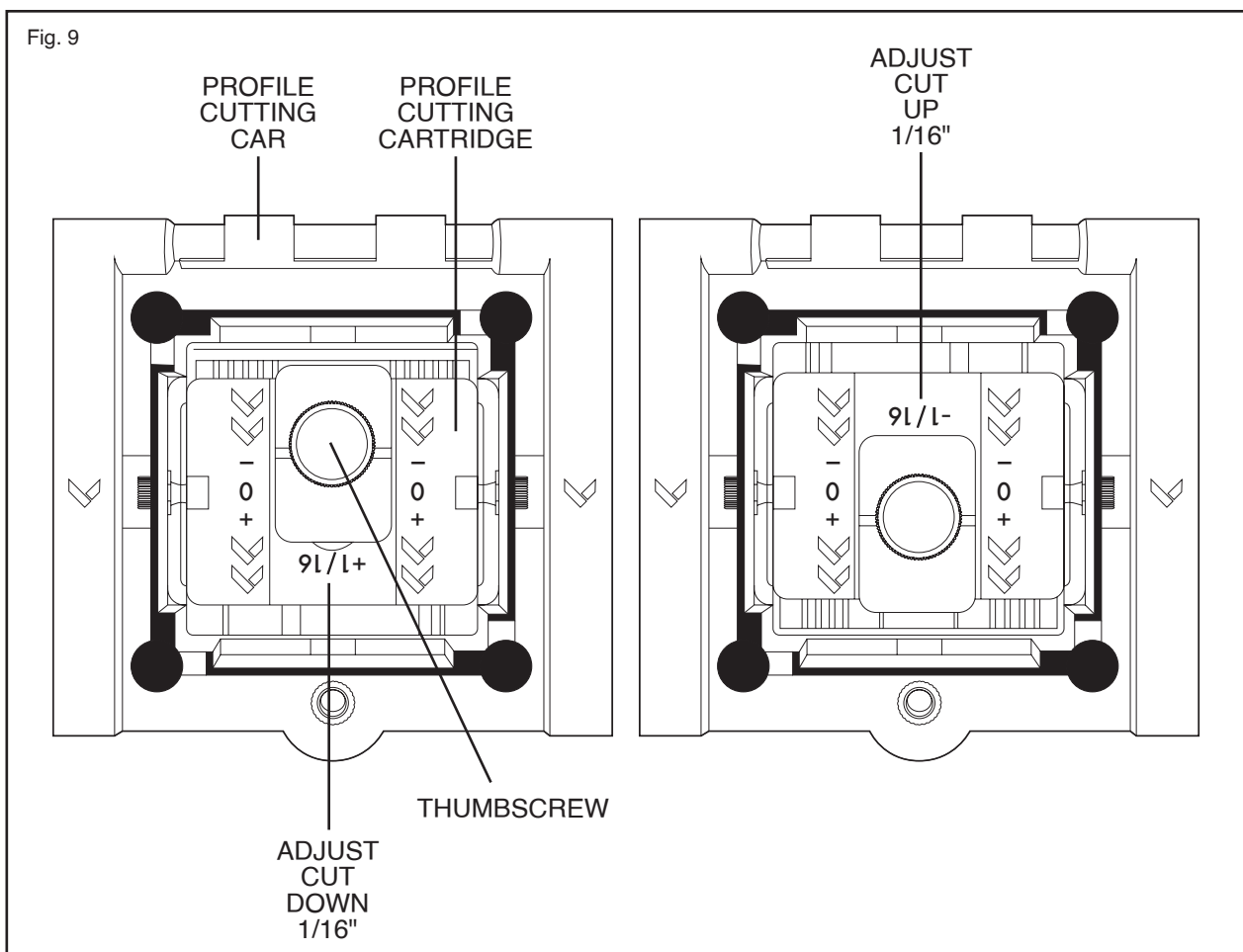

OUT-OF-SQUARE CUTS

Square cuts are easy with RevealCut. With the tile set flush against the tile stop and the rear end of the tile aligned with the desired measurement on the ruler, you are assured a straight, accurate cut every time. But walls and grids often can be out of square. This requires a change in the cutting procedure.

- Begin with both cutting cars at the top of the rails.
- Set jig stops to desired measurements on the top ruler and bottom ruler. (Fig. 10) The right side grid measurement is set at top ruler. The left side grid measurement is set at bottom ruler.
- Place tile finished face up on the platform.
- Align the rear of the tile so that it is flush with the preset jig stops instead of the tile stop. This will offset the tile to the correct dimensions. **Do not use tile stop for out-of-square cuts.**
- Use your hand to hold tile down gently on platform.
- Grasp long handle of sizing car and pull sizing blade down to the bottom of the rail. Make a complete pass. There is no need to try to cut the tile in a single pass. For many mineral fiber tiles you will need to make two or up to three passes of the sizing blade to cut completely through the tile. This is normal. Fiberglass tiles will usually require only a single pass.
- On final sizing pass, leave sizing car on bottom of rails, opposite the profile car.
- Next, make a single pass with the profile car to finish the tile edge.
- Remove tile.
- Return profile car to top of rail.

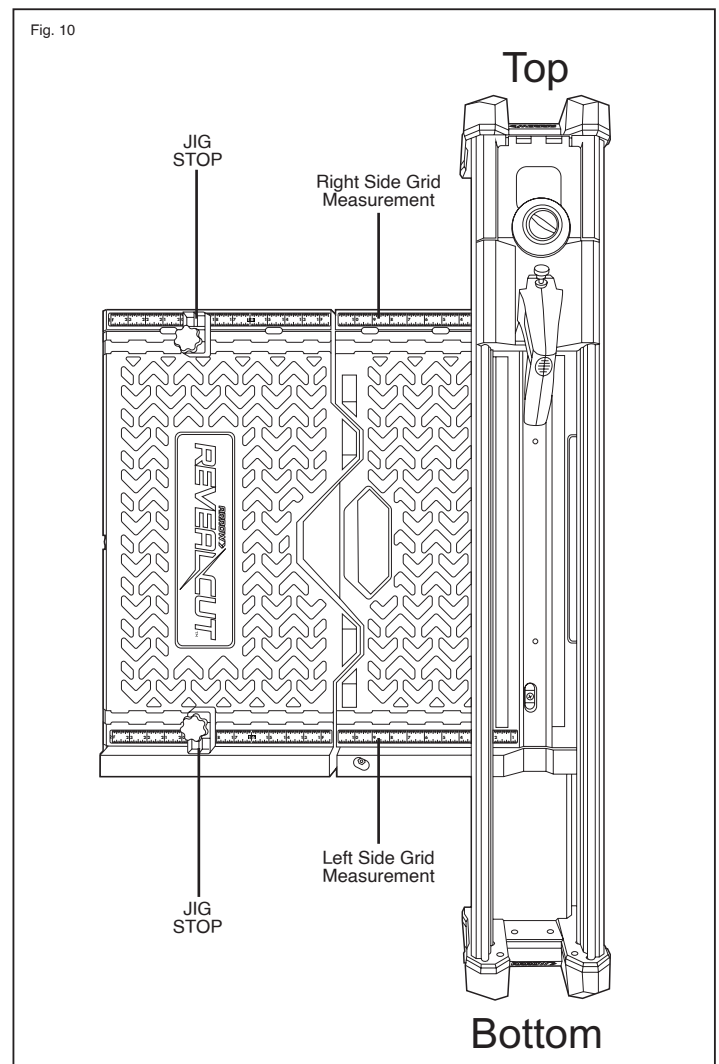

REPEAT AND LINEAR LIGHTING CUTS

Repeat and linear lighting cuts are fast and easy with the RevealCut jig stop design.

Repeat Cuts

- Begin with both cutting cars at the top position on the rails.
- Set jig stops to desired size.
- Place tile finished face up on the platform.
- Ensure tile is flush to the tile stop on platform. This ensures tile is square to the cutting blades.
- Align rear of tile to the jig stops.
- Cut and finish tile edge.
- Repeat with multiple tiles as needed.

Linear Lighting Cuts

- Begin with both cutting cars at top of the rails.
- Set jig stops to desired size.
- Place tile finished face up on the platform.
- Ensure tile is flush to the tile stop on the platform. This ensures tile is square to the cutting blades.
- Align rear of tile to the jig stops.
- Cut and finish tile edge. Remove tile.
- Return cutting cars to the top position on the rails.
- Reverse the cut tile and place it on the cutting platform.
- Ensure tile is flush to the tile stop on platform. This ensures tile is square to the cutting blades.
- Align rear of tile to the jig stops.
- Cut and finish opposite tile edge.

USING PLATFORM EXTENSION BARS (RC400 MODEL ONLY)

When cutting large-format tiles on the RC400 Model, the tile will often extend beyond the platform. For example, when cutting a 4' x 4' tile, the back of the tile will extend up to 2' beyond the rear edge of the RevealCut platform. For this reason, the RC400 comes with extension bars which snap into the platforms on the far side of the platform, away from the rails. These bars will support the larger tile sizes and minimize the risk of damage or warping of tiles during the cutting procedure. When finished using, remove the bars before storing the RevealCut unit. (Fig. 11)

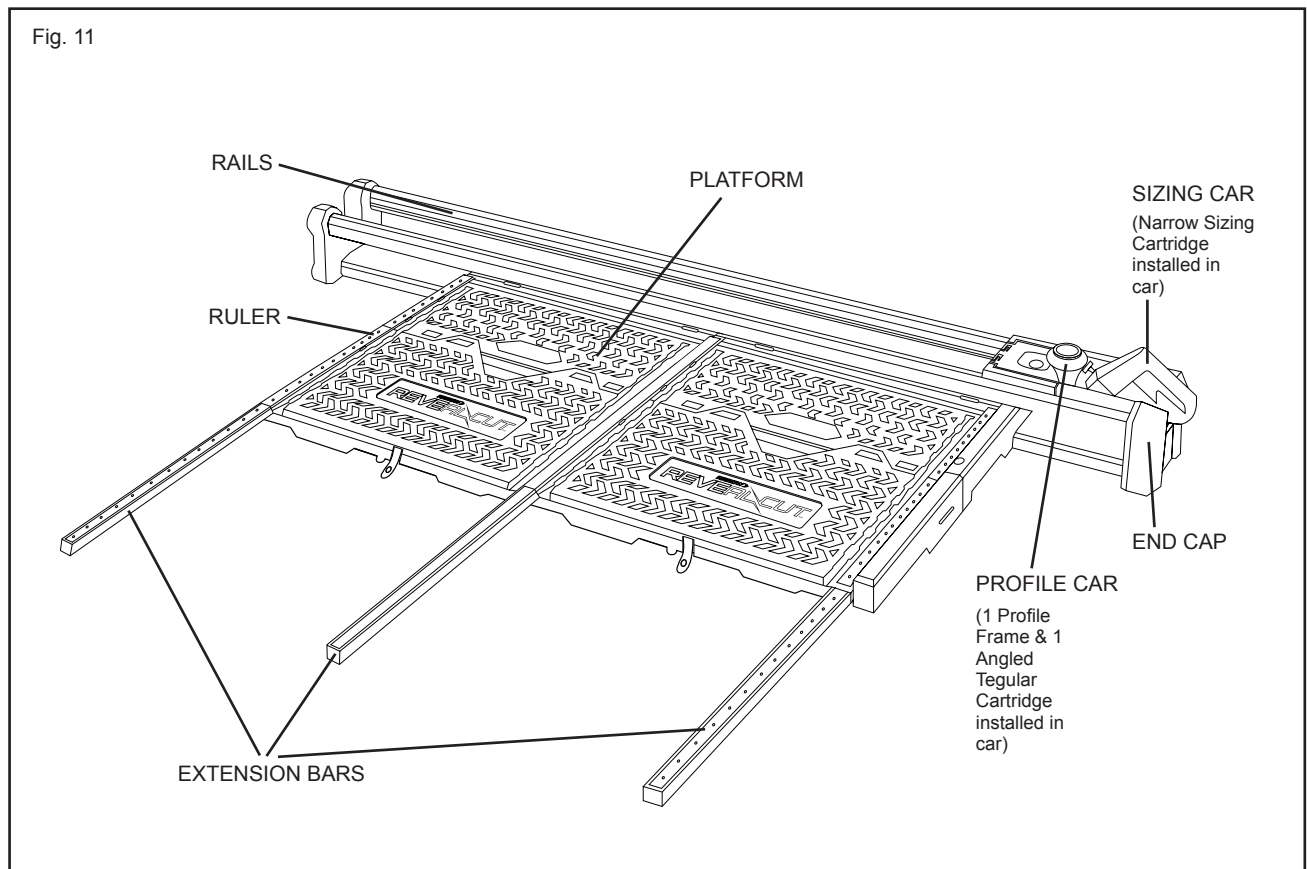

MAINTENANCE

Your RevealCut workstation requires little maintenance. For long-term, trouble-free performance observe the following guidelines:

- Remove and dispose of used blades when workstation is not in use. Use sharps container to dispose of blades.
- After each use, brush or wipe tile dust accumulation from workstation.
- Always store accessory bag between rails when not in use.
- Use storage bag provided to transport and store workstation and accessories.
- If cars begin to experience increased friction on rails, wiping rails down with a common clothes dryer sheet will restore smooth operation.
- Always keep the workstation dry and away from excessive moisture. Never put the workstation away wet.
- Mounting screws and extra thumbscrews are provided in the Parts Kit to replace any items that get lost on the jobsite.

TROUBLESHOOTING

Here are solutions to some of the common problems RevealCut users may encounter.

- **Cannot remove/install blade in Sizing Car:** Position sizing car at least 4" from the end cap at the bottom of the rail to allow handle to move freely.
- **Sizing cut is curved, not straight:** Sizing blade is not mounted flush in sizing cartridge. Remove sizing cartridge from sizing car housing and remove blade from cartridge. Reinstall making sure blade is flat against cartridge body.
- **Profile Cartridge doesn't cut:** Cartridge is installed backwards. Lift cover of profile car and reorient cartridge/frame assembly so that arrows on cartridge match arrows on car.
- **Profile cut is too high or too low:** Lift cover of profile car. If adjustment needed is within $1/16$ " up or down, use large thumbscrew on top of cartridge to adjust. If greater than $1/16$ ", change to next frame size up or down. See *Cutting Tiles* section for complete instructions.
- **Cut is fuzzy or unclean:** Blade is dull. Replace blade.
- **Cut is not square:** Tile was not aligned properly on platform. Be sure tile makes full contact with tile stop to ensure straight cuts.
- **Sizing cartridge won't cut:** Tile is wrong thickness for sizing cartridge used. Switch to correct sizing cartridge.
- **Tile is wrong size:** Most likely, lip measurement was added incorrectly. Recheck lip size and re-measure grid. See *Measuring Tile to Size* section for complete instructions.

TECHNICAL QUESTIONS / SERVICE

For technical and service related questions call Arrow customer service at (800) 776-2228.

WARRANTY

ARROW REVEALCUT ONE YEAR WARRANTY

All parts of Arrow RevealCut are warranted to the original purchaser to be free from defects in material and workmanship for one year from purchase.

Arrow Fastener will repair or replace, FREE OF CHARGE, during the warranty period, any product that proves to be defective in material or workmanship under normal use. If repair is not practical, Arrow Fastener may elect to replace the product or refund the purchase price in exchange for return of the defective product.

Please contact Arrow RevealCut by calling 1-800-776-2228 or by writing:

Arrow Fastener Company, LLC 271 Mayhill Street Saddle Brook, NJ 07663 Attn: Product Warranty Department.

Labor charges incurred by original purchaser to repair the product are excluded. This limited warranty does not cover damage to the product relating to normal wear and tear, misuse, abuse or neglect. Proof of purchase from the original purchaser must be made available to Arrow Fastener for all warranty claims. This is the exclusive warranty by Arrow Fastener Company for its RevealCut products.

Limitation of Liability. ARROW FASTENER SHALL NOT BE RESPONSIBLE FOR SPECIAL, INCIDENTAL OR CONSEQUENTIAL DAMAGES WHETHER ARISING OUT OF BREACH OF WARRANTY, BREACH OF CONTRACT, TORT, OR OTHERWISE. Some states do not allow the exclusion of incidental or consequential damages, so the above exclusion and limitation may not apply to you.

This limited warranty gives you specific legal rights, and you also may have other rights which vary from state to state. In Canada, the above provisions are not intended to operate where prohibited by law and do not preclude the operation of any applicable provincial protection statute which may in certain circumstances extend the express warranty herein

Arrow Fastener Company, LLC
271 Mayhill St.
Saddle Brook, NJ 07930
(800) 776-2228