

Modified Truss Head Driller - Exterior

Steel Framing and Lath to Heavy-Gauge Steel

GRABBER
CONSTRUCTION PRODUCTS

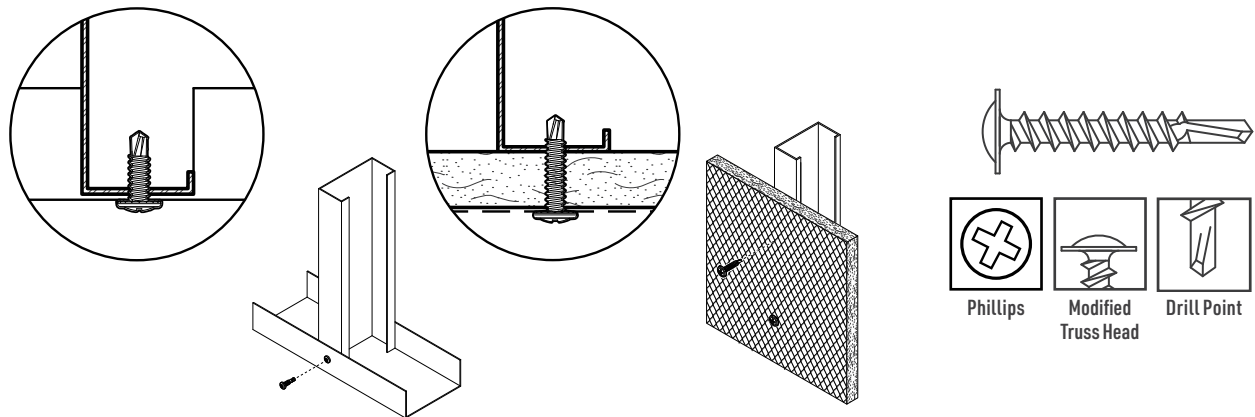

Description Attaches steel lath and heavy-gauge steel to heavy-gauge steel.

Specifications

Size | Gauge: #8 to #12
Length: 1/2 in. to 5 in.
Head Type: Modified Truss Head
Recess Type: #2 Phillips
Thread Type: Fine, Single Lead
Finish: GrabberGard®

Quality Assurance: Grabber® fasteners are manufactured in ISO 9001 and ISO 14001 certified and approved factories.

LEED Reporting: The post-consumer recycled steel content is 25%.

Compliance: The fasteners comply with ASTM C954 and C1513 performance requirements. Specific fasteners are listed in ICC ESR-1271; please check the report for listed item numbers.

Applications

- Heavy-gauge steel framing to heavy-gauge steel
- Heavy-gauge steel studs to door frame jamb anchor clips

- Heavy-gauge steel studs to track
- K-lath to heavy-gauge steel

Installation

- Use a standard screw gun with a depth-sensitive nose piece. Suggested screw gun specification for optimal performance: sizes #8 to #12, up to 2,500 RPM.
- Because of significantly higher torque output, care and caution should be exercised when using an impact driver; otherwise, screw failure or spin-out may occur.

- The modified truss head is fully seated when the bearing surface is flush with the work surface.
- The fastener must penetrate beyond the steel three full thread pitches.
- Overdriving may result in failure of the fastener.

Features

- Modified truss head design provides a larger load-bearing surface for better holding power.
- Heavier shank ensures entry in clips of hard steel.
- Self-tapping drill point is designed for penetration into heavy-gauge steel.
- Consistently formed extra-sharp drill point starts and drills easily into heavy-gauge steel.
- GrabberGard® exterior-grade coating provides additional protection against corrosion in most exterior applications.

Modified Truss Head Driller - Exterior Steel Framing and Lath to Heavy-Gauge Steel

GRABBER
CONSTRUCTION PRODUCTS

Standard Corrosion Test Results

Finish	Test	Standard/Protocol	Results
GrabberGard®	Salt Spray	ASTM B117	1,000 hrs., no red rust

Note: Salt Spray Testing (SST) results are not intended to predict corrosion in real-world environments. The ASTM B117 standard for SST is recognized industry-wide as an effective tool for comparing different metals and different metal coatings in a tightly controlled, highly corrosive environment for specific periods of time. For more information about corrosion resistance, see the Grabber Guide to Corrosion Resistance for Fasteners.

Pull-Out Test Data¹

Screw Gauge	TPI ²	Steel Gauge	Design Thickness	Tension	Shear
#8	18	18	0.0451 in.	94 lbs.	244 lbs.
		16	0.0566 in.	171 lbs.	344 lbs.
		14	0.0713 in.	215 lbs.	486 lbs.
		12	0.1017 in.	307 lbs.	827 lbs.
		10	0.1242 in.	375 lbs.	1,114 lbs.
#10	16	18	0.0451 in.	109 lbs.	263 lbs.
		16	0.0566 in.	198 lbs.	370 lbs.
		14	0.0713 in.	249 lbs.	523 lbs.
		12	0.1017 in.	356 lbs.	891 lbs.
		10	0.1242 in.	434 lbs.	1,199 lbs.
#12	14	18	0.0451 in.	124 lbs.	280 lbs.
		16	0.0566 in.	225 lbs.	394 lbs.
		14	0.0713 in.	284 lbs.	557 lbs.
		12	0.1017 in.	405 lbs.	950 lbs.
		10	0.1242 in.	493 lbs.	1,278 lbs.

¹Test data values reported are allowable as determined by calculations and industry established test criteria, such as ICC-ES Acceptance Criteria and ASTM test standards. Please contact Grabber for detailed information about testing performed for specific products or if ultimate values are needed.

Sheet Steel Gauges

Gauge No.	Design Thickness	Millimeter Equivalent
25	0.0188 in.	0.4775 mm
20	0.0346 in.	0.8788 mm
18	0.0451 in.	1.1455 mm
16	0.0566 in.	1.4376 mm
14	0.0713 in.	1.8110 mm
12	0.1017 in.	2.5832 mm
10	0.1242 in.	3.1547 mm

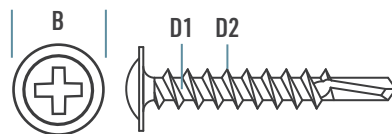

Product Dimensions

Screw Gauge	B Head Dia.	Recess Depth	D1 Minor Dia.	D2 Major Dia.	TPI ²
#8	0.447 in.	#2 Phillips	0.112 in.	0.164 in.	18
#10	0.447 in.	#2 Phillips	0.132 in.	0.190 in.	16
#12	0.447 in.	#2 Phillips	0.161 in.	0.216 in.	14

²TPI stands for Threads Per Inch. This is a count of the number of threads per inch measured along the length of a fastener.

Modified Truss Head Driller - Exterior

Steel Framing and Lath to Heavy-Gauge Steel



Ordering Information and Product Options

Item No.	Size	Recess	Head Diameter	TPI	Quantity	Weight	Special Features
GrabberGard® Gray							
34RG	8 x 1/2 in.	#2 Phillips	0.447 in.	18	10,000	40 lb.	ICC ESR-1271
35RG	8 x 1 in.	#2 Phillips	0.447 in.	18	5,000	30 lb.	
36RG	8 x 1 1/4 in.	#2 Phillips	0.447 in.	18	5,000	35 lb.	
37RG	8 x 1 5/8 in.	#2 Phillips	0.447 in.	18	4,000	34 lb.	
234RG	8 x 1/2 in.	#2 Phillips	0.447 in.	18	10,000	40 lb.	
240G	10 x 3 1/2 in.	#2 Phillips	0.447 in.	16	1,000	21 lb.	
241G	10 x 4 in.	#2 Phillips	0.447 in.	16	800	20 lb.	
242G	10 x 5 in.	#2 Phillips	0.447 in.	16	500	15 lb.	
23412CWRG	12 x 3/4 in.	#2 Phillips	0.447 in.	14	5,000	33 lb.	ICC ESR-1271
23410CWRG	10 x 3/4 in.	#2 Phillips	0.447 in.	16	4,000	39 lb.	

Note: Product availability is subject to change without prior notice and the availability of products may differ from what is printed in literature and displayed on our website. The items listed are bulk size. Most are also available in smaller package sizes such as 5 lb. and 1 lb. Contact your local Grabber Branch or GrabberPro for more information.

Modified Truss Head Driller - Exterior
PS1044 USA-ENG/Rev. 05-25

GRABBER CONSTRUCTION PRODUCTS, INC.
5255 W 11000 N., STE 100
HIGHLAND, UT 84003

(800) 477-8876 | GrabberPro.com

SAFETY FIRST: Wear appropriate personal protective equipment. Read applicable SDS and literature before handling and installation.

TECHNICAL INFORMATION: Technical information contained herein is furnished without charge or obligation and is given and accepted at the recipient's sole risk. Because conditions of use may vary and are beyond our control, Grabber Construction Products makes no representation about, and is not responsible or liable for, the accuracy or reliability of data associated with uses of any product described herein. Grabber Construction Products reserves the right to modify this document without prior notice.

© 2025 Grabber Construction Products, Inc. | All rights reserved | Printed in U.S.A.
The trademarks Grabber, GrabberGard, and Stylized G on Grabber Fasteners, are trademarks of Grabber Construction Products, Inc.

