

Flat Head Wood-to-Wood Screw

Interior Wood

GRABBER®
CONSTRUCTION PRODUCTS

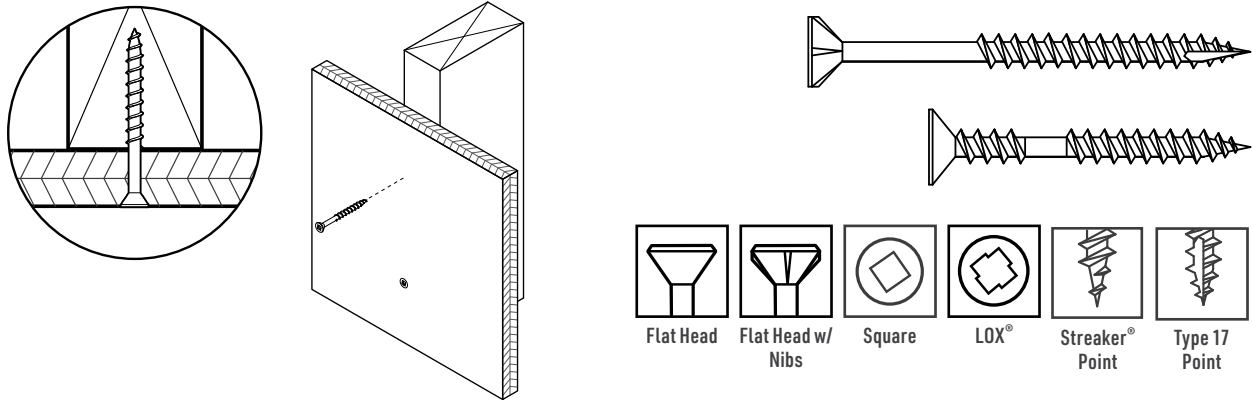

Description

For interior wood projects such as cabinets, paneling, furniture, wood framing, stairs, wood trim, and more.

Specifications

Size | Gauge: #8 to #10

Length: 1 in. to 6 in.

Head Type: Flat, Flat w/nibs

Recess Type: #2 Square, #2 LOX®, #3 LOX®

Thread Type: Single Lead and Double Lead, Coarse

Finish: Clear Zinc, Yellow Zinc

Quality Assurance: Grabber® fasteners are manufactured in ISO 9001 and ISO 14001 certified and approved factories.

LEED Reporting: The post-consumer recycled steel content is 25%.

Applications

- Interior wood-to-wood applications
- General interior wood construction
- Cabinet construction and mounting
- Countertop construction
- Furniture construction
- Wood paneling

Installation

- Use a standard screw gun with a depth-sensitive nose piece. Suggested screw gun specification for optimal performance: sizes #8 to #10, up to 4,000 RPM.
- The flat head is fully seated when it is flush with the work surface.
- The fastener should penetrate the wood at least 3/4 in., in accordance with AWC-NDS for wood construction.
- Overdriving may result in failure of the fastener.

Features

- Square recess is a precision recess designed for secure bit engagement in wood-to-wood applications.
- LOX® recess allows for ultimate torque and will not strip out like most other recesses.
- The flat head design provides better holding power in wood-to-wood applications.
- Underhead nibs ensure flush countersinking.
- TwinFast double-lead thread drives faster through OSB subfloor.
- Type 17 point is designed to smoothly penetrate wood without cracking the surface.

Flat Head Wood-to-Wood Screw

Interior Wood



Standard Corrosion Test Results

Finish	Test	Standard/Protocol	Results
Clear Zinc	Salt Spray	ASTM B117	12 hrs., no red rust
Yellow Zinc	Salt Spray	ASTM B117	24 hrs., no red rust

Note: Salt Spray Testing (SST) results are not intended to predict corrosion in real-world environments. The ASTM B117 standard for SST is recognized industry-wide as an effective tool for comparing different metals and different metal coatings in a tightly controlled, highly corrosive environment for specific periods of time. For more information about corrosion resistance, refer to Grabber's Coatings and Corrosion Resistance Classifications in the Technical Data section of Grabber Fastener Solutions, PG1000. Consult with a corrosion specialist or the architect or engineer of record for detailed guidance and recommendations specific to your project.

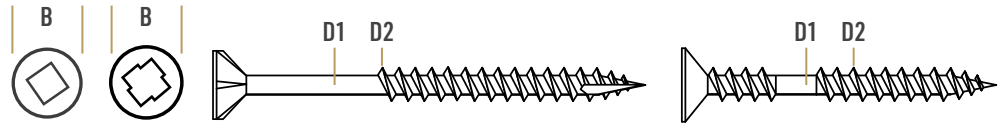

Product Dimensions

Size	B Head Dia.	Recess	D1 Minor Dia.	D2 Major Dia.	TPI ¹
#8	0.309 in.	#2 Square	0.116 in.	0.164 in.	8
#9	0.337 in.	#2 Square	0.124 in.	0.177 in.	8
#10	0.363 in.	#2 Square	0.132 in.	0.190 in.	8
#8	0.309 in.	#2 LOX [®]	0.116 in.	0.164 in.	8
	0.344 in.	#2 LOX [®]	0.116 in.	0.164 in.	10
	0.346 in.	#3 LOX [®]	0.116 in.	0.164 in.	10
	0.354 in.	#2 LOX [®]	0.114 in.	0.164 in.	10
#9	0.337 in.	#2 LOX [®]	0.124 in.	0.177 in.	8
#10	0.363 in.	#2 LOX [®]	0.132 in.	0.190 in.	8

¹TPI stands for Threads Per Inch. This is a count of the number of threads per inch measured along the length of a fastener.

Ordering Information and Product Options

Item No.	Size	Recess	Head Diameter	TPI ¹	Qty.	Weight	Special Features
Clear Zinc							
78100Z	8 x 1 in.	#2 Square	0.309 in.	8	8,000	33 lb.	Woody, Underhead nibs, Type 17 point
78118Z	8 x 1 1/8 in.	#2 Square	0.309 in.	8	6,000	29 lb.	
78125Z	8 x 1 1/4 in.	#2 Square	0.309 in.	8	6,000	30 lb.	
78150Z	8 x 1 1/2 in.	#2 Square	0.309 in.	8	5,000	30 lb.	
78175Z	8 x 1 3/4 in.	#2 Square	0.309 in.	8	4,000	28 lb.	
78200Z	8 x 2 in.	#2 Square	0.309 in.	8	3,000	24 lb.	
782508Z	8 x 2 1/2 in.	#2 Square	0.309 in.	8	2,500	25 lb.	
78250Z	9 x 2 1/2 in.	#2 Square	0.337 in.	8	2,500	30 lb.	
78275Z	9 x 2 3/4 in.	#2 Square	0.337 in.	8	2,000	25 lb.	
783008Z	8 x 3 in.	#2 Square	0.309 in.	8	2,000	24 lb.	
78300Z	9 x 3 in.	#2 Square	0.337 in.	8	2,000	28 lb.	
78350Z	10 x 3 1/2 in.	#2 Square	0.363 in.	8	1,000	20 lb.	
78400Z	10 x 4 in.	#2 Square	0.363 in.	8	1,000	22 lb.	

¹TPI stands for Threads Per Inch. This is a count of the number of threads per inch measured along the length of a fastener.

Flat Head Wood-to-Wood Screw

Interior Wood

GRABBER
CONSTRUCTION PRODUCTS

Ordering Information and Product Options (continued)

Item No.	Size	Recess	Head Diameter	TPI ¹	Qty.	Weight	Special Features
Yellow Zinc							
WL8100YZ	8 x 1 in.	#2 LOX [®]	0.309 in.	8	8,000	33 lb.	Underhead nibs, Type 17 point
WL8150YZ	8 x 1 1/2 in.	#2 LOX [®]	0.309 in.	8	5,000	29 lb.	
WL8200YZ	8 x 2 in.	#2 LOX [®]	0.309 in.	8	3,000	23 lb.	
WL9250YZ	9 x 2 1/2 in.	#2 LOX [®]	0.337 in.	8	2,500	29 lb.	
WL9300YZ	9 x 3 in.	#2 LOX [®]	0.337 in.	8	2,000	28 lb.	
WL10350YZ	10 x 3 1/2 in.	#2 LOX [®]	0.363 in.	8	1,000	20 lb.	
WL10400YZ	10 x 4 in.	#2 LOX [®]	0.363 in.	8	1,000	22 lb.	
78118YZ	8 x 1 1/8 in.	#2 Square	0.309 in.	8	6,000	29 lb.	Woody, Underhead nibs, Type 17 point
78125YZ	8 x 1 1/4 in.	#2 Square	0.309 in.	8	6,000	30 lb.	
78150YZ	8 x 1 1/2 in.	#2 Square	0.309 in.	8	5,000	30 lb.	
78175YZ	8 x 1 3/4 in.	#2 Square	0.309 in.	8	4,000	28 lb.	
78200YZ	8 x 2 in.	#2 Square	0.309 in.	8	3,000	24 lb.	
782508YZ	8 x 2 1/2 in.	#2 Square	0.309 in.	8	2,500	25 lb.	
78250YZ	9 x 2 1/2 in.	#2 Square	0.337 in.	8	2,500	30 lb.	
78275YZ	9 x 2 3/4 in.	#2 Square	0.337 in.	8	2,000	25 lb.	
7830010YZ	10 x 3 in.	#2 Square	0.363 in.	8	1,500	30 lb.	
783008YZ	8 x 3 in.	#2 Square	0.309 in.	8	2,000	24 lb.	
78300YZ	9 x 3 in.	#2 Square	0.337 in.	8	2,000	28 lb.	
78350YZ	10 x 3 1/2 in.	#2 Square	0.363 in.	8	1,000	20 lb.	
78400YZ	10 x 4 in.	#2 Square	0.363 in.	8	1,000	22 lb.	
78500YZ	10 x 5 in.	#2 Square	0.363 in.	8	1,000	26 lb.	
78600YZ	10 x 6 in.	#2 Square	0.363 in.	8	1,000	33 lb.	
W8100YZ	8 x 1 in.	#2 LOX [®]	0.309 in.	8	5,000	33 lb.	Underhead nibs, Type 17 point
W8150YZ	8 x 1 1/2 in.	#2 LOX [®]	0.309 in.	8	5,000	29 lb.	
W8175YZ	8 x 1 3/4 in.	#2 LOX [®]	0.309 in.	8	2,500	19 lb.	
W8200YZ	8 x 2 in.	#2 LOX [®]	0.309 in.	8	3,000	23 lb.	
W9250YZ	9 x 2 1/2 in.	#2 LOX [®]	0.337 in.	8	2,500	29 lb.	
W9300YZ	9 x 3 in.	#2 LOX [®]	0.337 in.	8	2,000	28 lb.	Collated, TwinFast Double Threads, Streaker [®] Point
C8175L3YZ	8 x 1 3/4 in.	#3 LOX [®]	0.346 in.	10	1,000	5 lb.	
C8175LYZ	8 x 1 3/4 in.	#2 LOX [®]	0.346 in.	10	1,000	5 lb.	
C8200L3YZ	8 x 2 in.	#3 LOX [®]	0.346 in.	10	1,000	5 lb.	
C8200L2YZ	8 x 2 in.	#2 LOX [®]	0.346 in.	10	1,000	5 lb.	
C8250L3YZ	8 x 2 1/2 in.	#3 LOX [®]	0.346 in.	10	1,000	5 lb.	
C8250LYZ	8 x 2 1/2 in.	#2 LOX [®]	0.346 in.	10	1,000	5 lb.	
C8300L3YZ	8 x 3 in.	#3 LOX [®]	0.346 in.	10	1,000	5 lb.	Collated, Streaker [®] Point
C8175SFJBW	8 x 1 3/4 in.	#2 LOX [®]	0.344 in.	10	1,000	5 lb.	
C8200SFJBW	8 x 2 in.	#2 LOX [®]	0.344 in.	10	1,000	5 lb.	
C8250SFJBW	8 x 2 in.	#2 LOX [®]	0.344 in.	10	1,000	5 lb.	
C8300SFJBW	8 x 2 in.	#2 LOX [®]	0.344 in.	10	1,000	5 lb.	

¹TPI stands for Threads Per Inch. This is a count of the number of threads per inch measured along the length of a fastener.

Note: Product availability is subject to change without prior notice and the availability of products may differ from what is printed in literature and displayed on our website. The items listed are bulk size. Most are also available in smaller packages such as 5 lb. and 1 lb. Contact your local Grabber Branch or GrabberPro for more information.

Flat Head Wood Screw
PS1020 USA-ENG/Rev. 02-25

GRABBER CONSTRUCTION PRODUCTS, INC.
5255 W 11000 N., STE 100
HIGHLAND, UT 84003

(800) 477-8876 | GrabberPro.com

SAFETY FIRST: Wear appropriate personal protective equipment. Read applicable SDS and literature before handling and installation.

TECHNICAL INFORMATION: Technical information contained herein is furnished without charge or obligation and is given and accepted at the recipient's sole risk. Because conditions of use may vary and are beyond our control, Grabber Construction Products makes no representation about, and is not responsible or liable for, the accuracy or reliability of data associated with uses of any product described herein. Grabber Construction Products reserves the right to modify this document without prior notice.

© 2025 Grabber Construction Products, Inc. | All rights reserved | Printed in U.S.A.

The trademarks Grabber, LOX, Streaker, and Stylized G on Grabber Fasteners, are trademarks of Grabber Construction Products, Inc.

