

# Hex Head Streaker®

## Light-Gauge Steel Framing

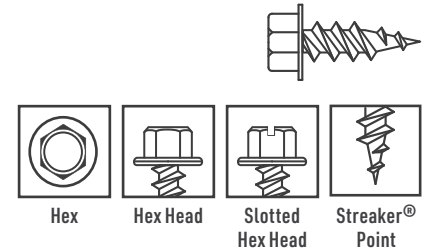
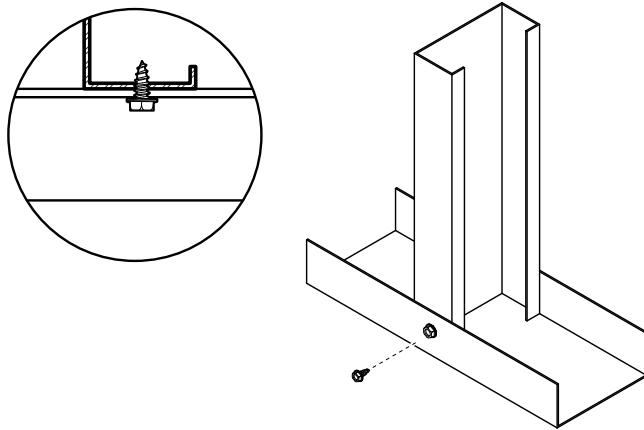

**Description** Light-gauge sheet steel and framing.

**Specifications**

**Size | Gauge:** #8 and #10  
**Length:** 1/2 in. to 1 1/2 in.  
**Head Type:** Hex Head, Slotted Hex Head  
**Recess Type:** 1/4 in. to 5/16 in. Hex  
**Thread Type:** Fine, Single Lead  
**Finish:** Clear Zinc

**Quality Assurance:** Grabber® fasteners are manufactured in ISO 9001 and ISO 14001 certified and approved factories.  
**LEED Reporting:** The post-consumer recycled steel content is 25%.  
**Compliance:** The fasteners comply with ASTM C1513 performance requirements.

**Applications**

- Light-gauge steel studs to door frame jamb anchor clips
- Sheet steel and duct assembly
- Light-gauge steel-to-steel applications

**Installation**

- Suggested screw gun specification for optimal performance: sizes #8 and #10, up to 4,000 RPM.
- The hex head is fully seated when the bottom of the head is flush with the work surface.
- The fastener must penetrate beyond the steel three full thread pitches.
- Overdriving may result in failure of the fastener or strip-out.

**Features**

- Hex washer head design provides for maximum torque and holding power in light-gauge steel-to-steel applications.
- The hex washer head provides a larger load-bearing surface for better holding power.
- Extra-sharp, single lead 23° Streaker® point is designed to penetrate light-gauge steel quickly and easily.
- Certain items have slotted heads to allow tightening with a flat head screwdriver.
- Certain items have white painted heads.

# Hex Head Streaker®

## Light-Gauge Steel Framing



### Standard Corrosion Test Results

Finish	Test	Standard/Protocol	Results
Clear Zinc	Salt Spray	ASTM B117	12 hrs., no red rust

Note: Salt Spray Testing (SST) results are not intended to predict corrosion in real-world environments. The ASTM B117 standard for SST is recognized industry-wide as an effective tool for comparing different metals and different metal coatings in a tightly controlled, highly corrosive environment for specific periods of time. For more information about corrosion resistance, see the Grabber Guide to Corrosion Resistance for Fasteners.

### Pull-Out Test Data<sup>1</sup>

Screw Gauge	TPI <sup>2</sup>	Steel Gauge	Design Thickness	Tension	Shear
#8	15	25	0.0188 in.	39 lbs.	66 lbs.
		20	0.0346 in.	72 lbs.	164 lbs.
#10	12	25	0.0188 in.	46 lbs.	71 lbs.
		20	0.0346 in.	84 lbs.	177 lbs.

<sup>1</sup>Test data values reported are allowable as determined by calculations and industry established test criteria, such as ICC-ES Acceptance Criteria and ASTM test standards. Please contact Grabber for detailed information about testing performed for specific products or if ultimate values are needed.

### Sheet Steel Gauges

Gauge No.	Design Thickness	Millimeter Equivalent
25	0.0188 in.	0.4775 mm
20	0.0346 in.	0.8788 mm

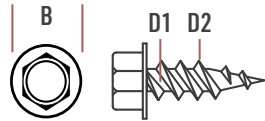

### Product Dimensions

Screw Gauge	B Head Dia.	Drive Type	D1 Minor Dia.	D2 Major Dia.	TPI <sup>2</sup>
#8	0.335 in.	1/4 in. Hex	0.108 in.	0.164 in.	15
	0.335 in.	1/4 in. Hex	0.109 in.	0.164 in.	15
	0.335 in.	1/4 in. Hex	0.113 in.	0.164 in.	15
	0.335 in.	1/4 in. Hex	0.119 in.	0.164 in.	15
#10	0.399 in.	5/16 in. Hex	0.118 in.	0.190 in.	12
	0.399 in.	5/16 in. Hex	0.127 in.	0.190 in.	12
	0.399 in.	5/16 in. Hex	0.130 in.	0.190 in.	12

<sup>2</sup>TPI stands for Threads Per Inch. This is a count of the number of threads per inch measured along the length of a fastener.

# Hex Head Streaker®

## Light-Gauge Steel Framing



### Ordering Information and Product Options

Item No.	Size	Drive Type	Head Diameter	TPI	Quantity	Weight	Special Features
Clear Zinc							
08075HSP	8 x 3/4 in.	1/4 in. Hex	.335 in.	15	2,000	46 lb.	Slotted hex head
08100HSP	8 x 1 in.	1/4 in. Hex	.335 in.	15	7,500	41 lb.	
08150HSP	8 x 1 1/2 in.	1/4 in. Hex	.335 in.	15	5,000	41 lb.	
08200HSP	8 x 2 in.	1/4 in. Hex	.335 in.	15	5,000	27 lb.	
08200HSPW	8 x 2 in.	1/4 in. Hex	.335 in.	15	5,000	27 lb.	White painted, Slotted hex head
10100HSP	10 x 1 in.	5/16 in. Hex	.399 in.	12	5,000	26 lb.	Slotted hex head
25100Z	8 x 1 in.	1/4 in. Hex	.335 in.	15	7,500	37 lb.	Slotted hex head
25SZ	8 x 9/16 in.	1/4 in. Hex	.335 in.	15	10,000	35 lb.	
25SLZ	8 x 9/16 in.	1/4 in. Hex	.335 in.	15	10,000	35 lb.	
SL03	8 x 1/2 in.	1/4 in. Hex	.335 in.	15	10,000	53 lb.	
SL10	10 x 3/4 in.	5/16 in. Hex	.399 in.	12	7,500	29 lb.	Slotted hex head
SL14	10 x 1 1/2 in.	5/16 in. Hex	.399 in.	12	5,000	36 lb.	
25150Z	8 x 1 1/2 in.	1/4 in. Hex	.335 in.	15	5,000	37 lb.	White painted hex head
25Z	8 x 9/16 in.	1/4 in. Hex	.335 in.	15	10,000	35 lb.	
25ZW	8 x 9/16 in.	1/4 in. Hex	.335 in.	15	10,000	35 lb.	White painted hex head
27Z	8 x 7/8 in.	1/4 in. Hex	.335 in.	15	7,500	41 lb.	

Note: Product availability is subject to change without prior notice and the availability of products may differ from what is printed in literature and displayed on our website. The items listed are bulk size. Most are also available in smaller package sizes such as 5 lb. and 1 lb. Contact your local Grabber Branch or GrabberPro for more information.

Hex Head Streaker®  
PS1023 USA-ENG/Rev. 05-25

GRABBER CONSTRUCTION PRODUCTS, INC.  
5255 W 11000 N., STE 100  
HIGHLAND, UT 84003

(800) 477-8876 | GrabberPro.com

**SAFETY FIRST:** Wear appropriate personal protective equipment. Read applicable SDS and literature before handling and installation.

**TECHNICAL INFORMATION:** Technical information contained herein is furnished without charge or obligation and is given and accepted at the recipient's sole risk. Because conditions of use may vary and are beyond our control, Grabber Construction Products makes no representation about, and is not responsible or liable for, the accuracy or reliability of data associated with uses of any product described herein. Grabber Construction Products reserves the right to modify this document without prior notice.

© 2025 Grabber Construction Products, Inc. | All rights reserved | Printed in U.S.A.  
The trademarks Grabber, Streaker, and Stylized G on Grabber Fasteners, are trademarks of Grabber Construction Products, Inc.

